

Introduction to Linked Open Data for Computational Mass Spectrometry

Institute of Organic Chemistry and Biochemistry of the Czech Academy of Sciences
Flemingovo náměstí 542/2

Adriano Rutz, 2024-04-17

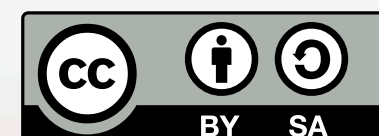

D BIOL

What is Linked Open Data (LOD)?

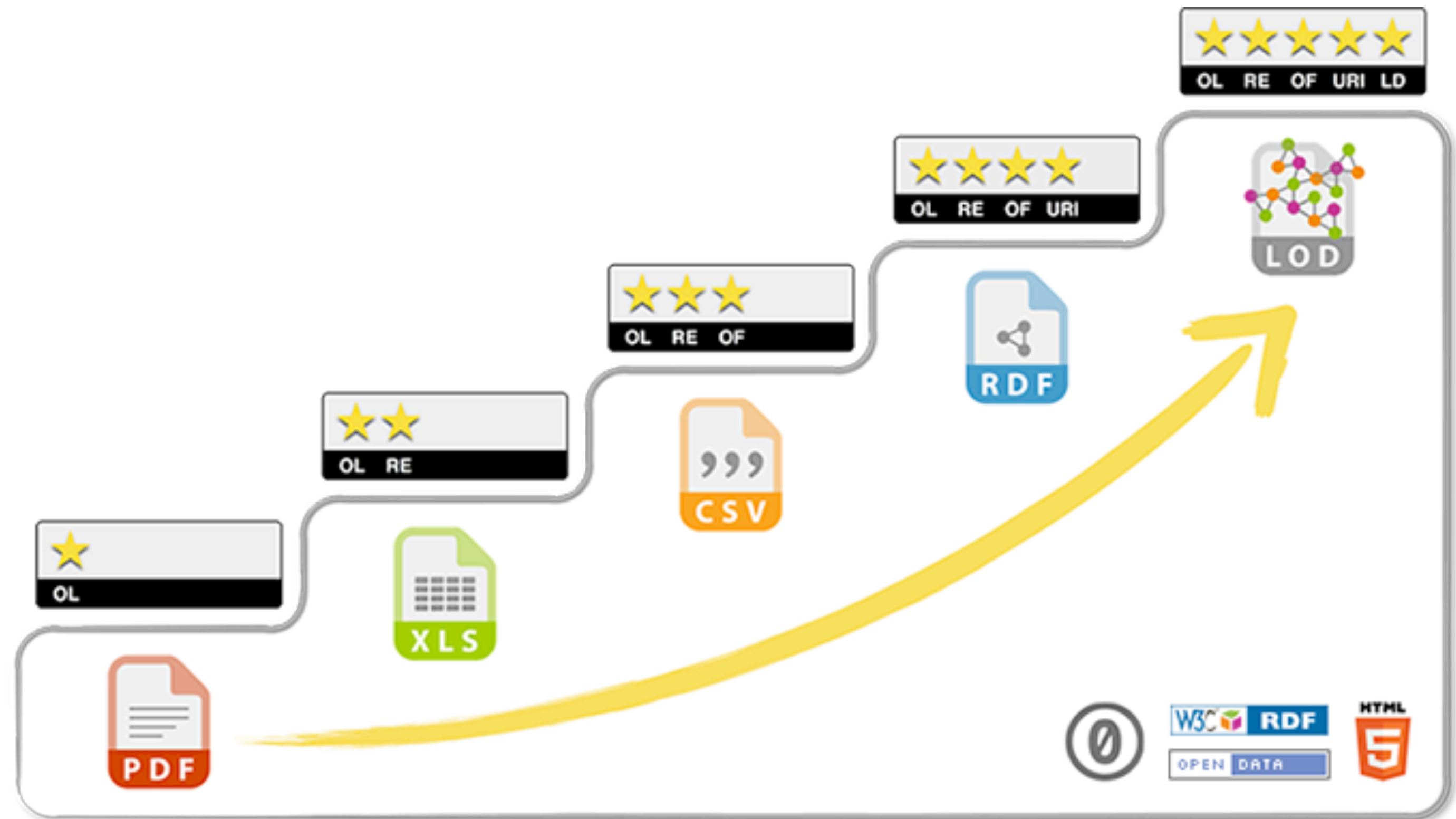

https://commons.wikimedia.org/wiki/File:5-star_deployment_scheme_for_Open_Data.png

What is Linked Open Data (LOD)?

make your *content* available on the Web (whatever format) under an open license

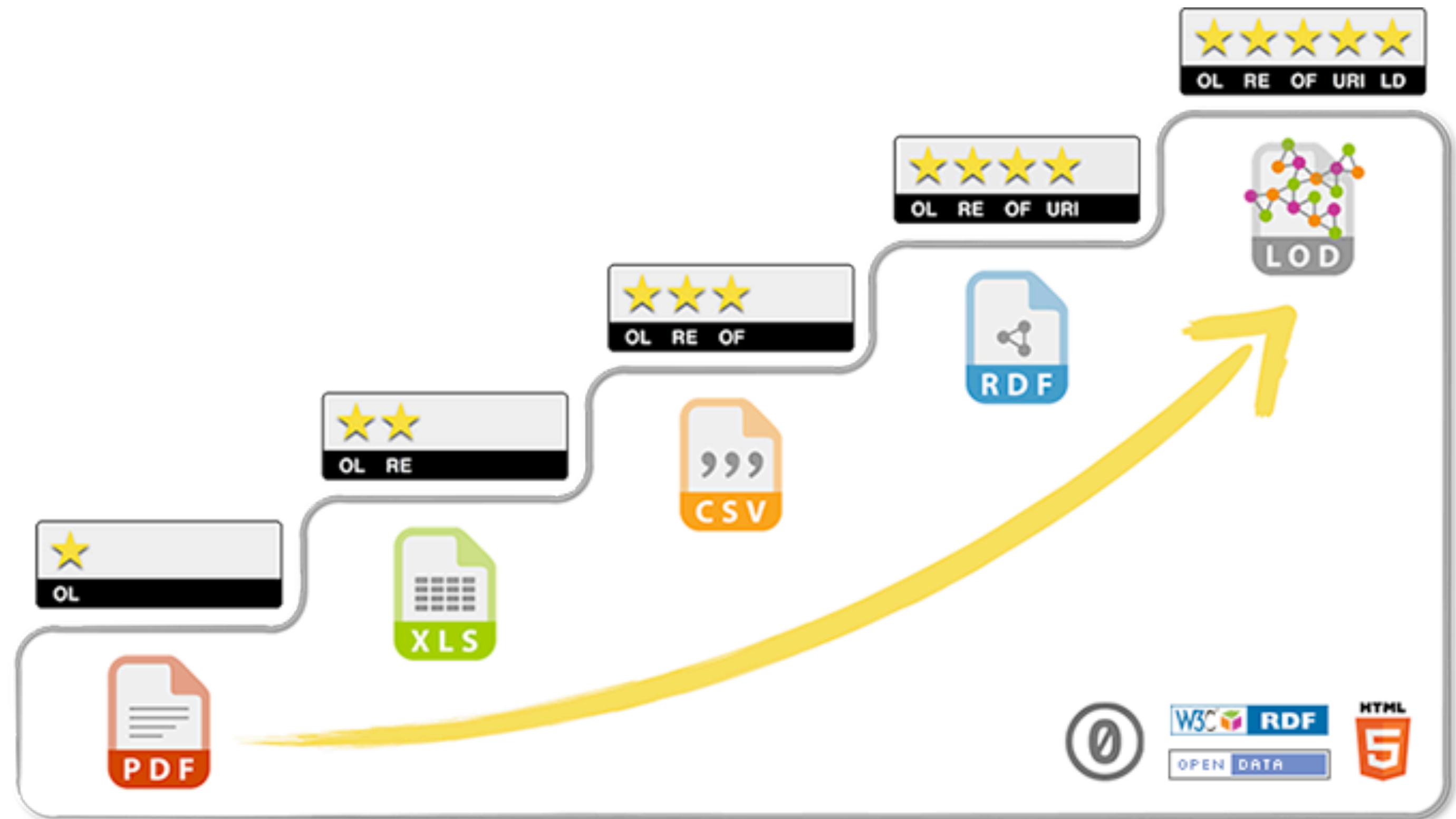

https://commons.wikimedia.org/wiki/File:5-star_deployment_scheme_for_Open_Data.png

<https://5stardata.info>

What is Linked Open Data (LOD)?

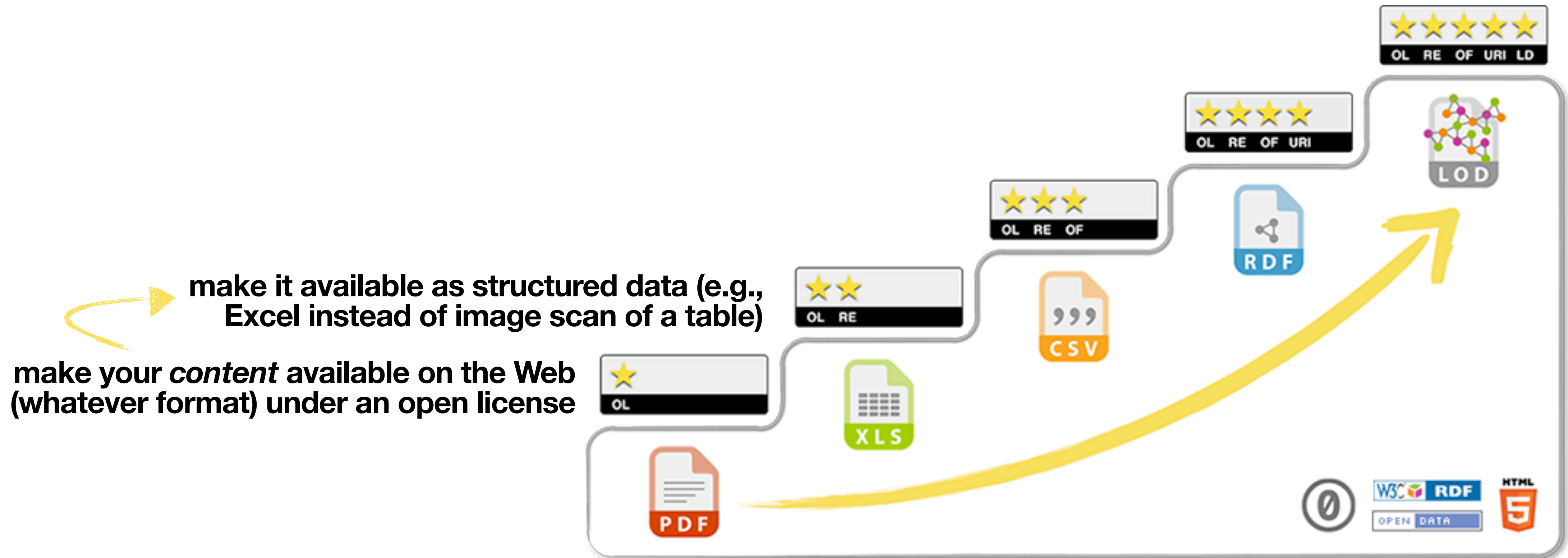

https://commons.wikimedia.org/wiki/File:5-star_deployment_scheme_for_Open_Data.png

<https://5stardata.info>

What is Linked Open Data (LOD)?

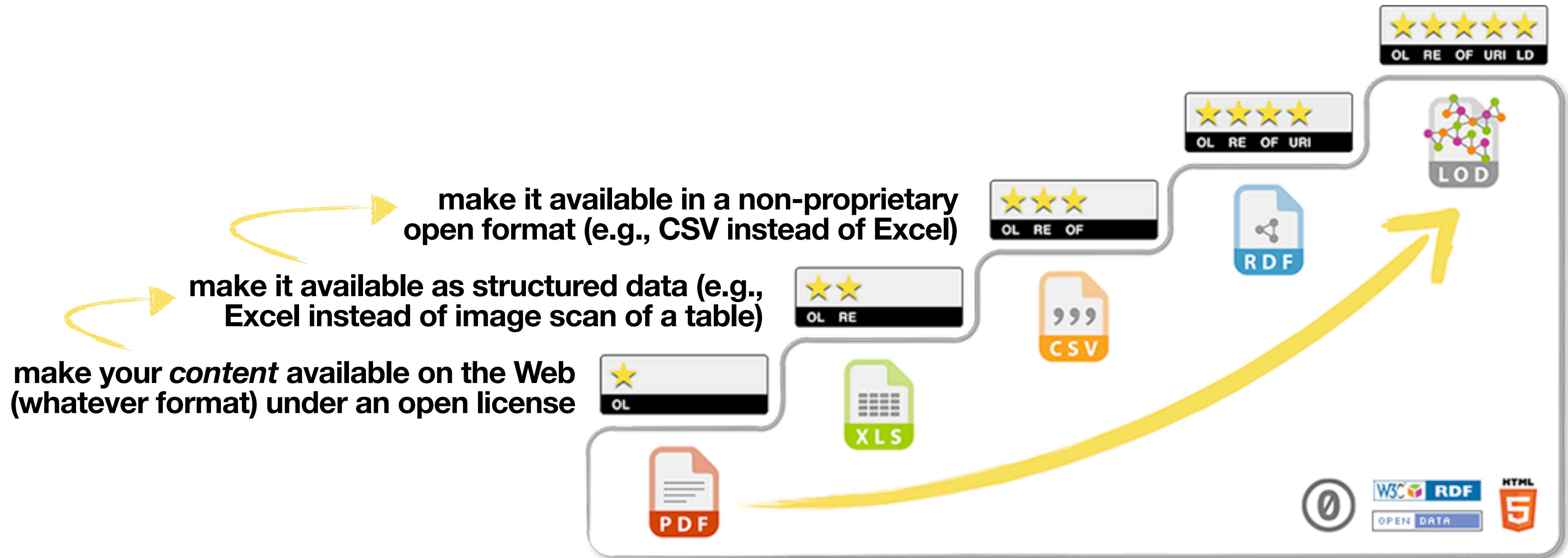

https://commons.wikimedia.org/wiki/File:5-star_deployment_scheme_for_Open_Data.png

<https://5stardata.info>

What is Linked Open Data (LOD)?

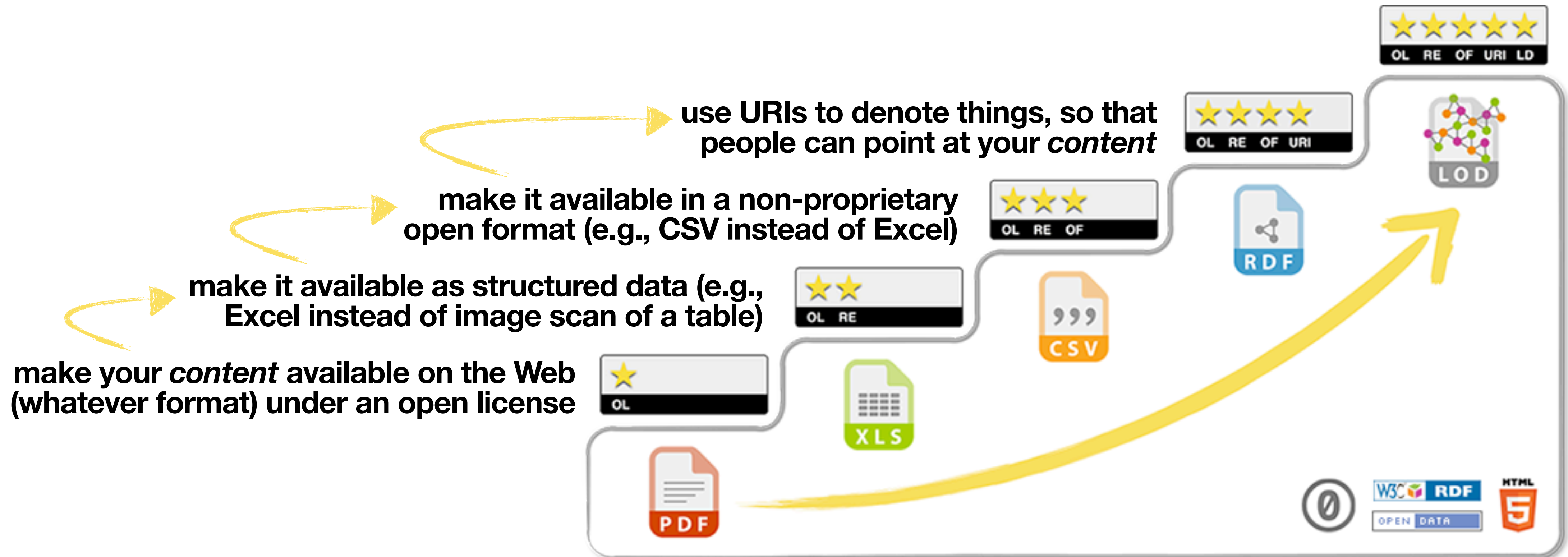

https://commons.wikimedia.org/wiki/File:5-star_deployment_scheme_for_Open_Data.png

<https://5stardata.info>

What is Linked Open Data (LOD)?

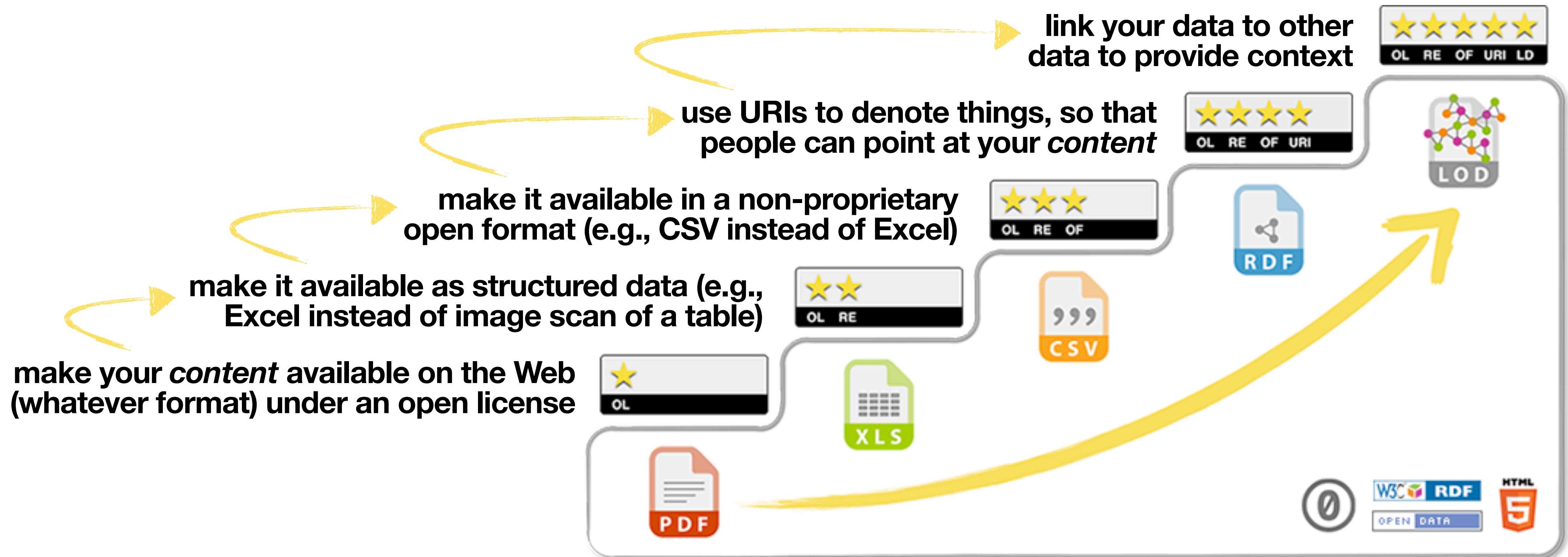

https://commons.wikimedia.org/wiki/File:5-star_deployment_scheme_for_Open_Data.png

What is Linked Open Data (LOD)?

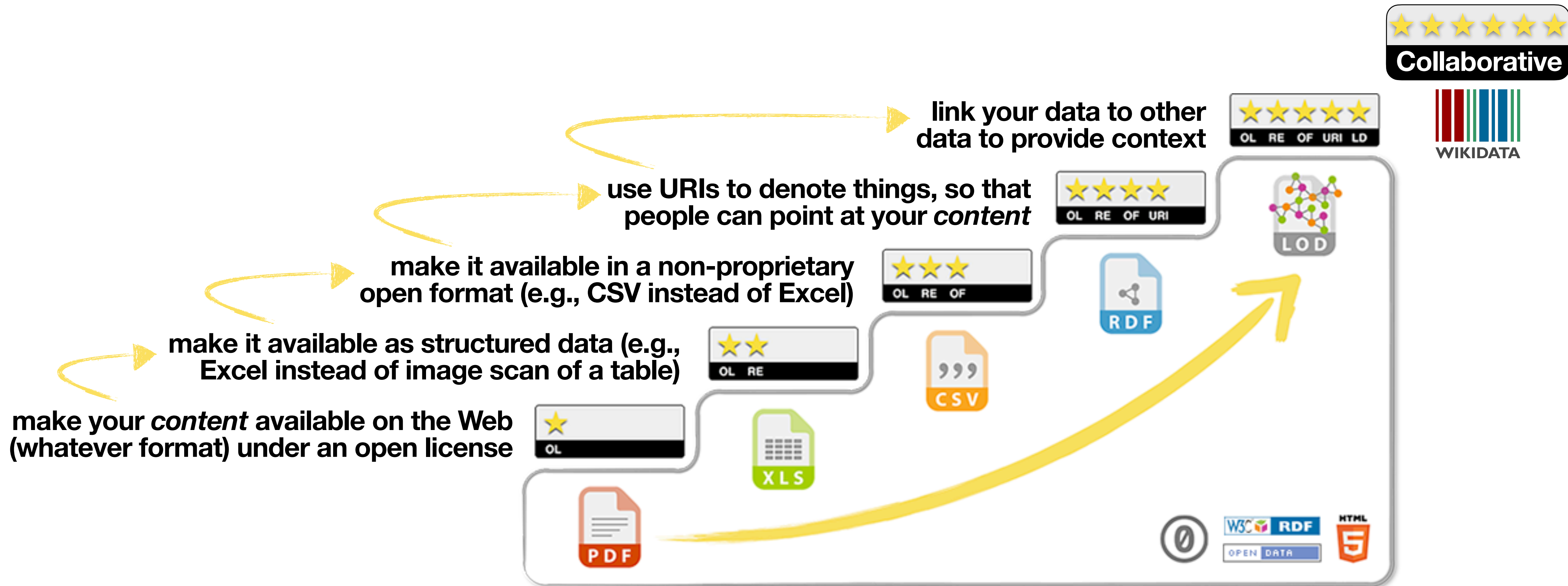

https://commons.wikimedia.org/wiki/File:5-star_deployment_scheme_for_Open_Data.png

<https://5stardata.info>

LOD as a *macroscope* for computational mass spectrometry

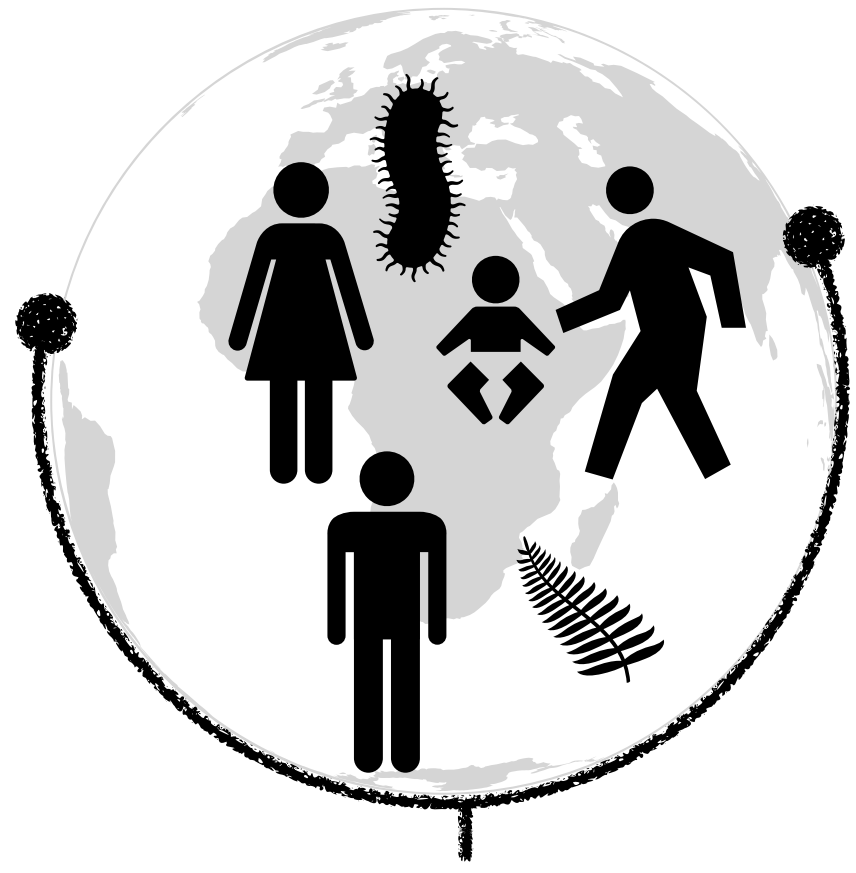

LOD as a *macroscope* for computational mass spectrometry

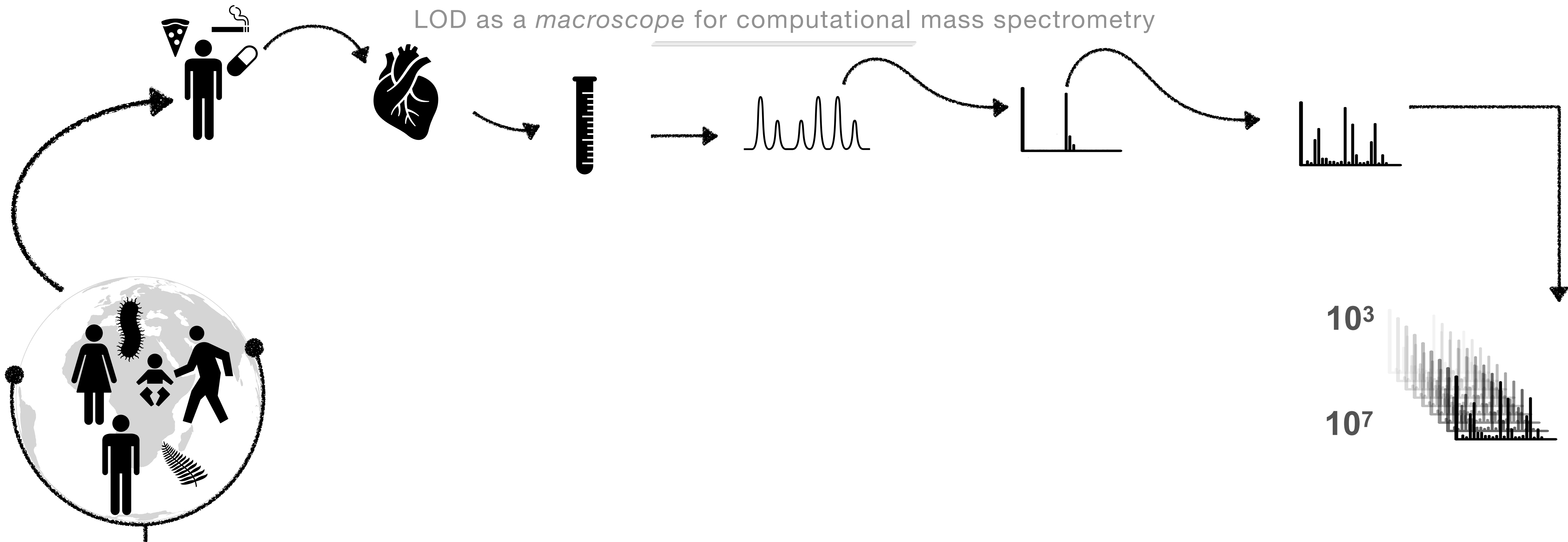

LOD as a *macroscope* for computational mass spectrometry

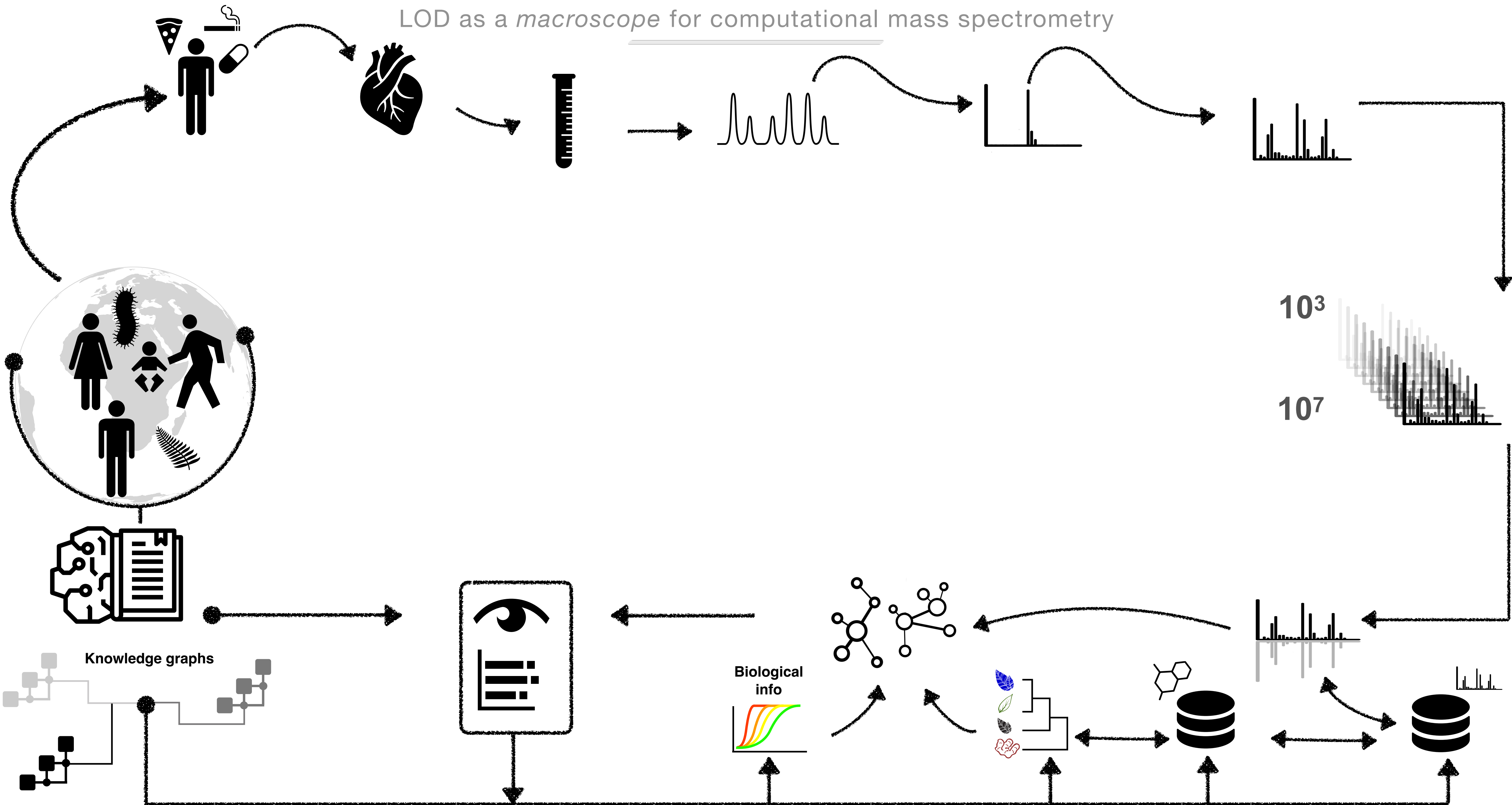

LOD as a *macroscope* for computational mass spectrometry

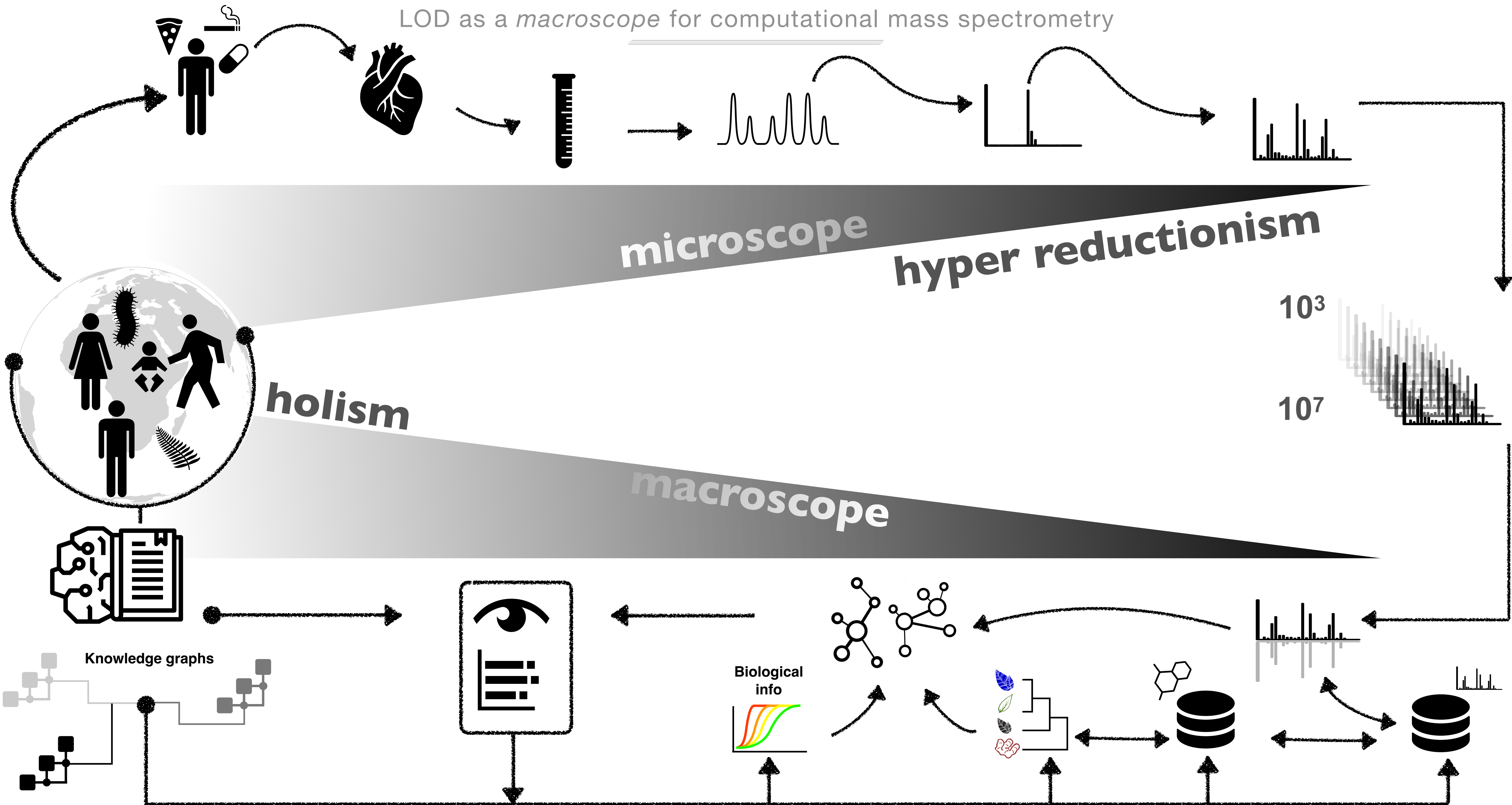

LOD as a *macroscope* for computational mass spectrometry

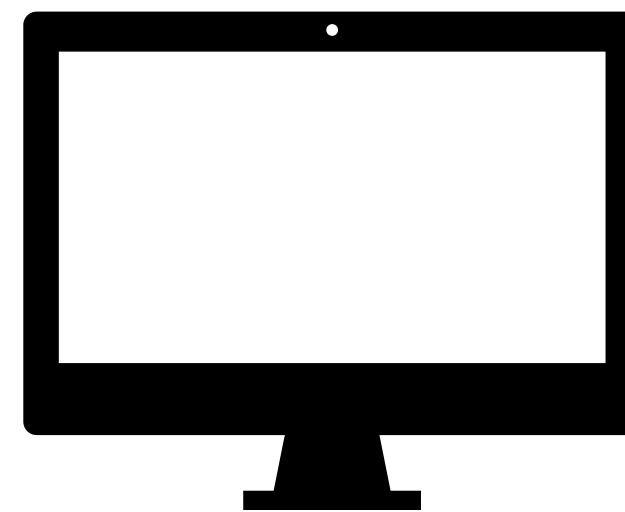
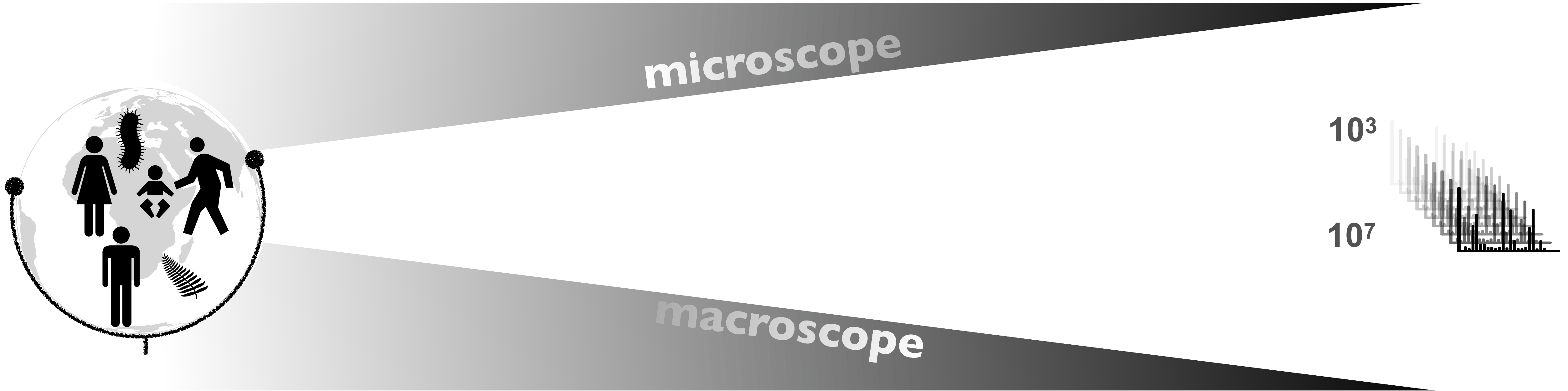
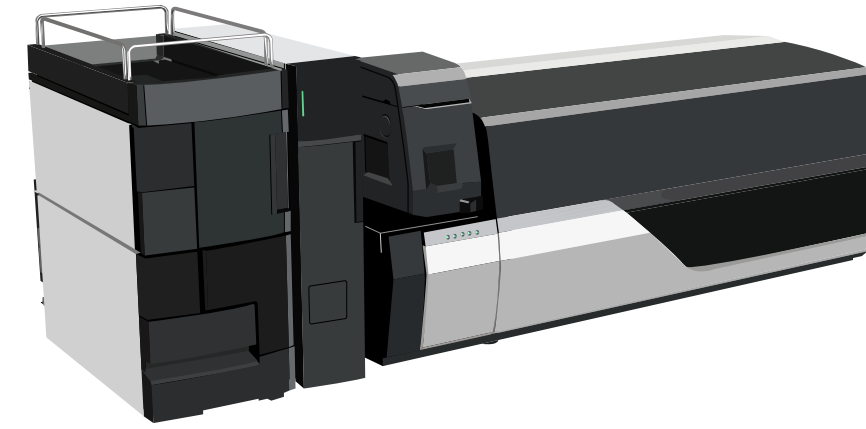

LOD as a *macroscope* for computational mass spectrometry

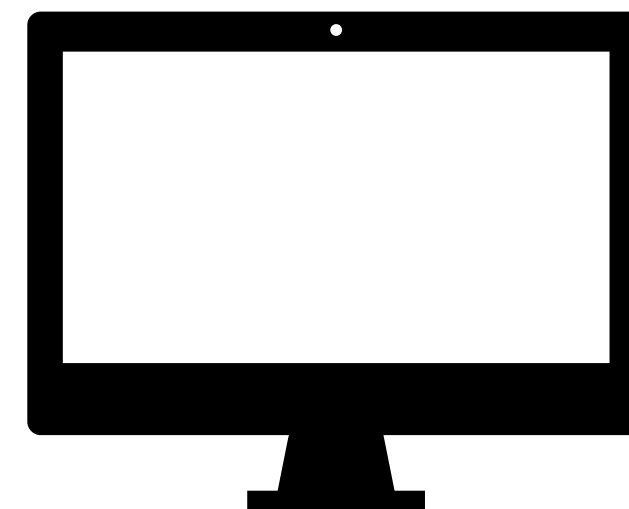
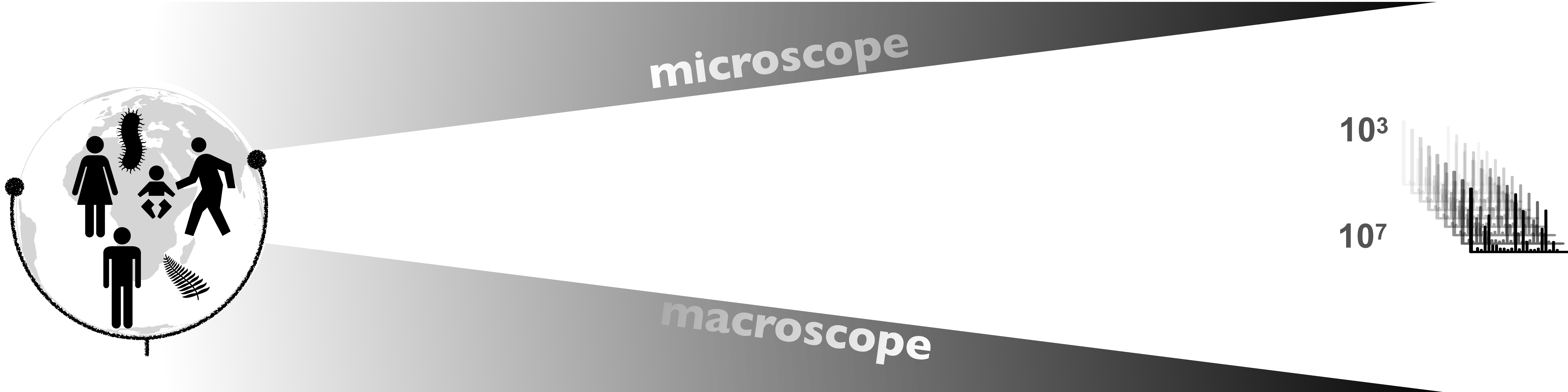
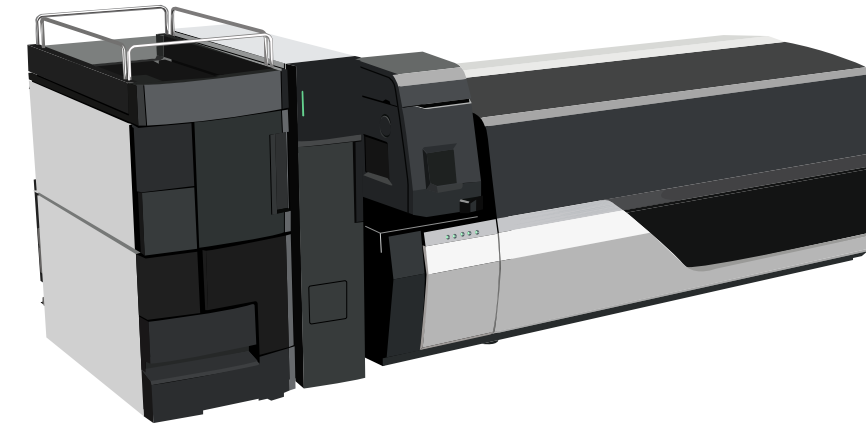

LOD as a *macroscope* for computational mass spectrometry

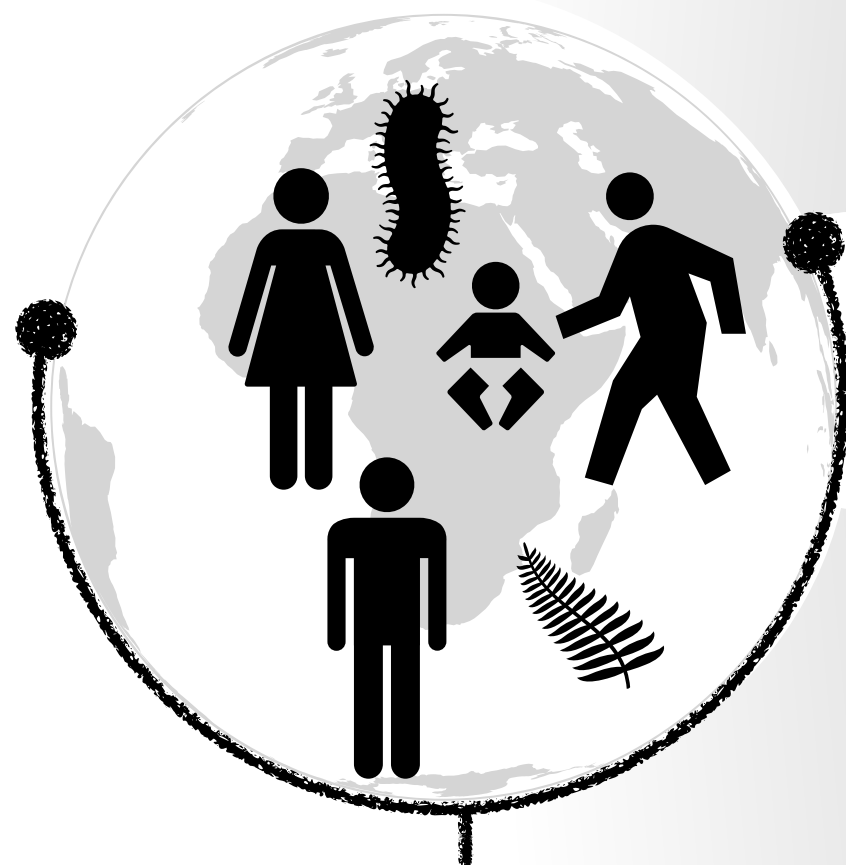
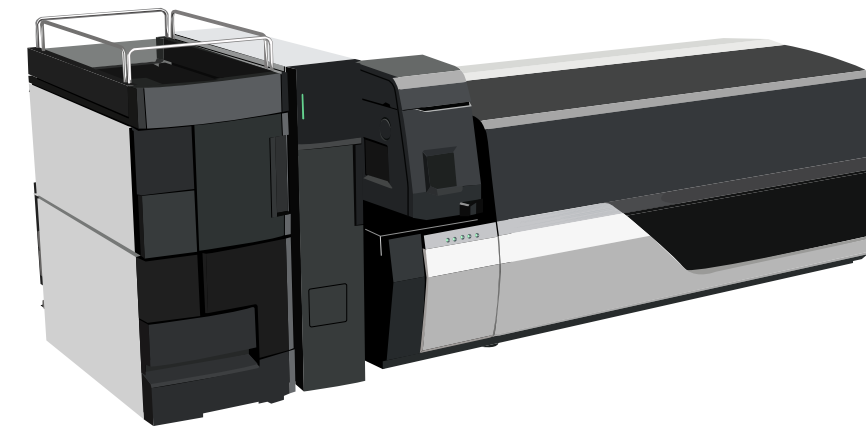

microscope

macroscope



mzmine

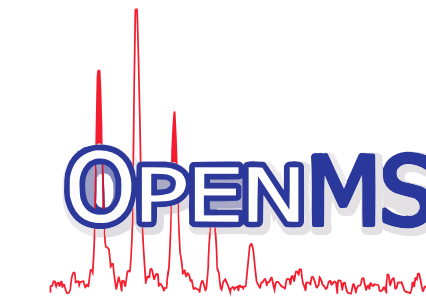

10^3

10^7

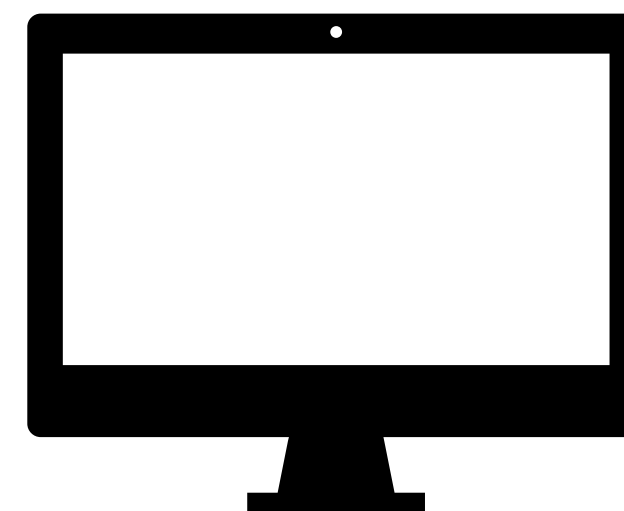
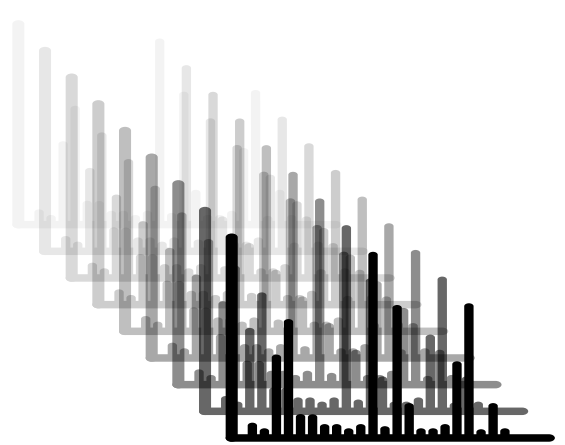

LOD as a *macroscope* for computational mass spectrometry

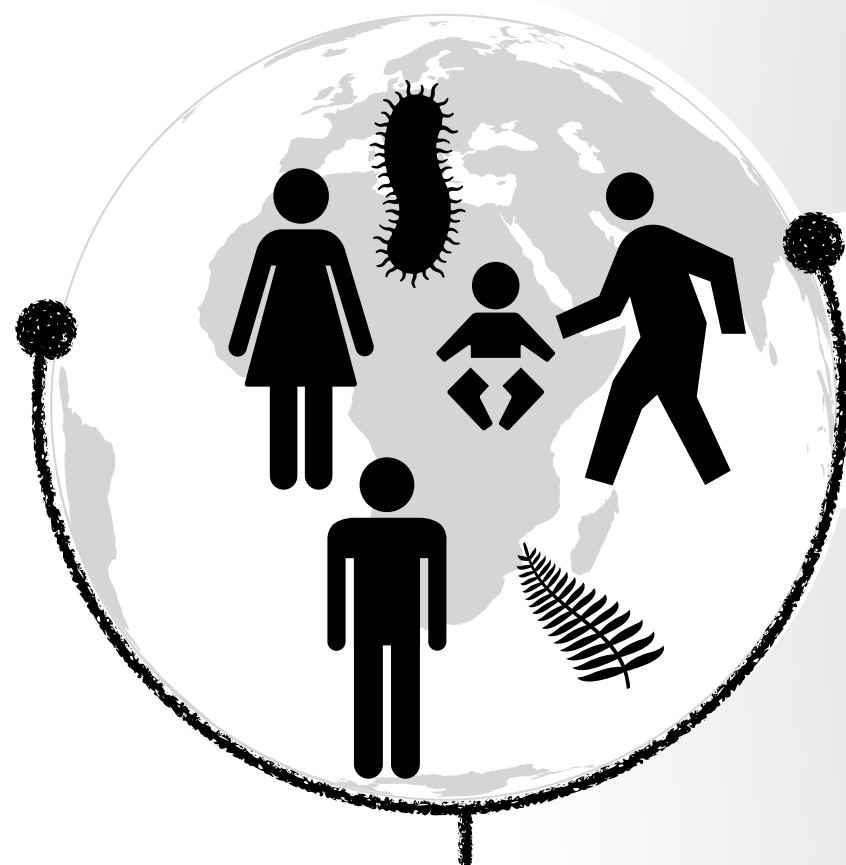
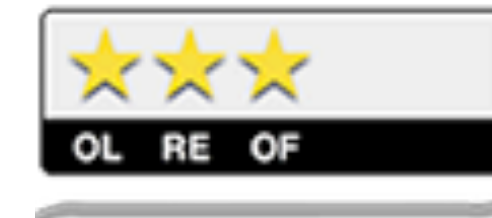
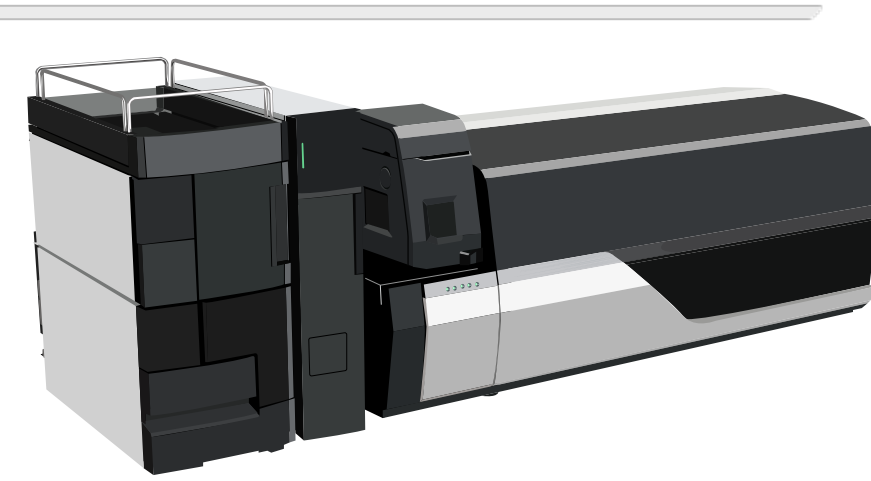

microscope

macroscope

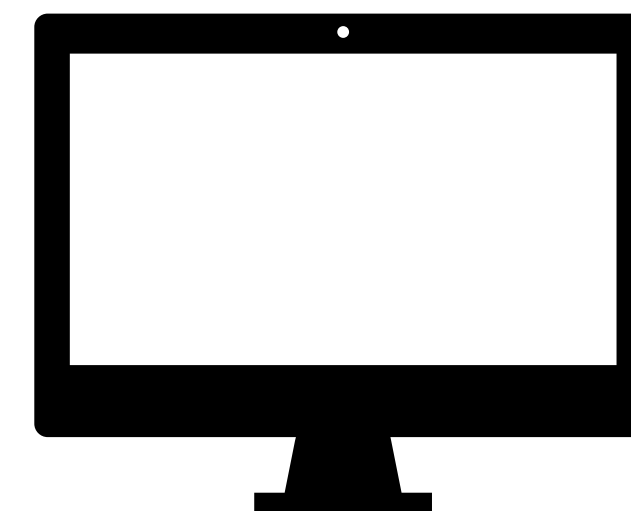
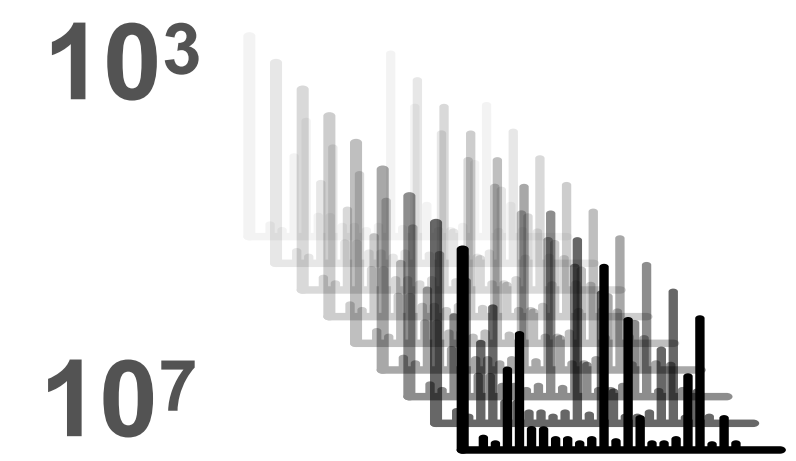

LOD as a *macroscope* for computational mass spectrometry

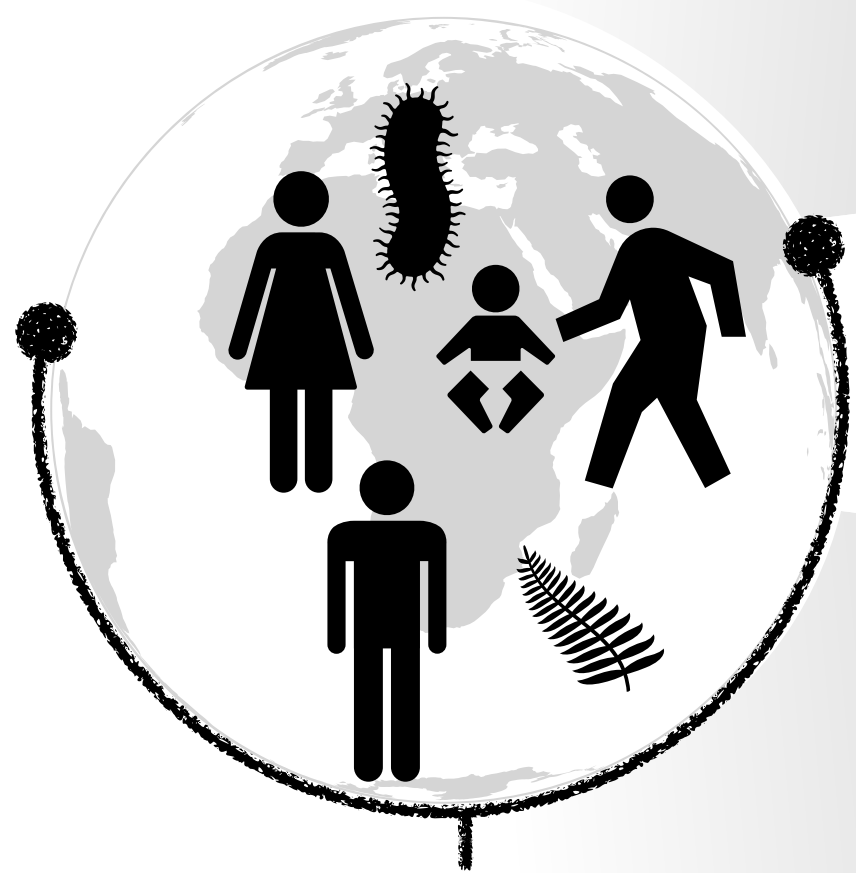
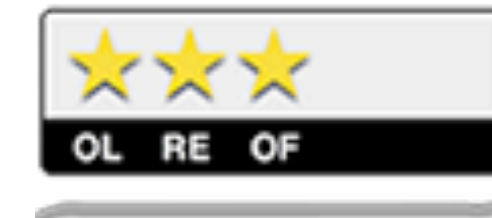
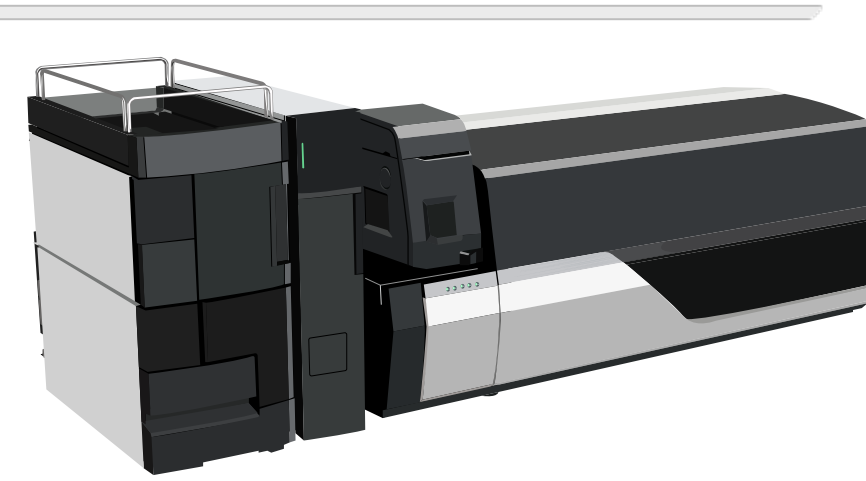

microscope

macroscope

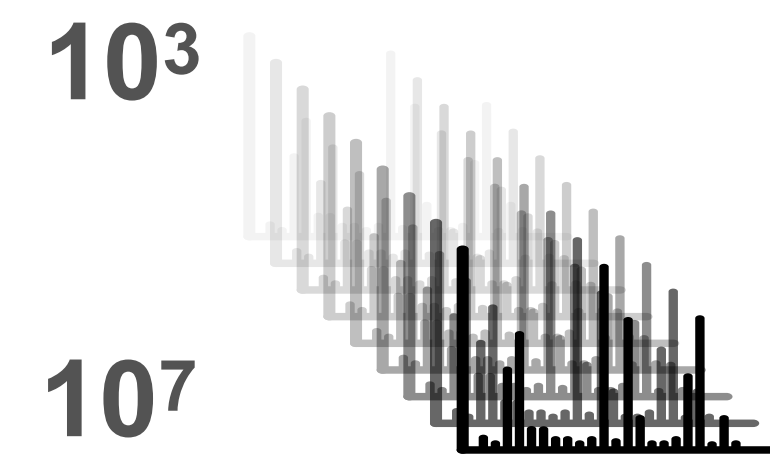

LOD as a *macroscope* for computational mass spectrometry

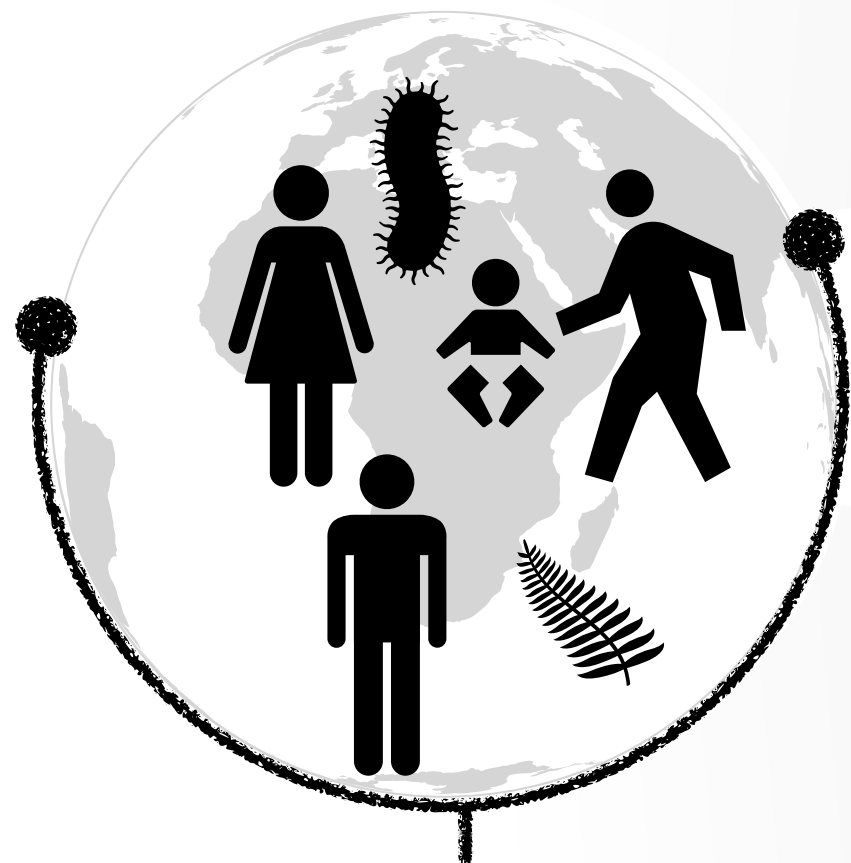
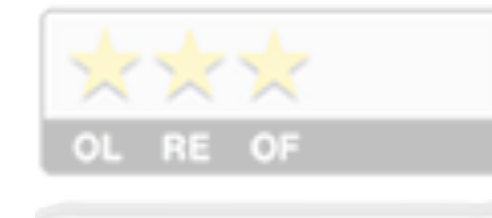
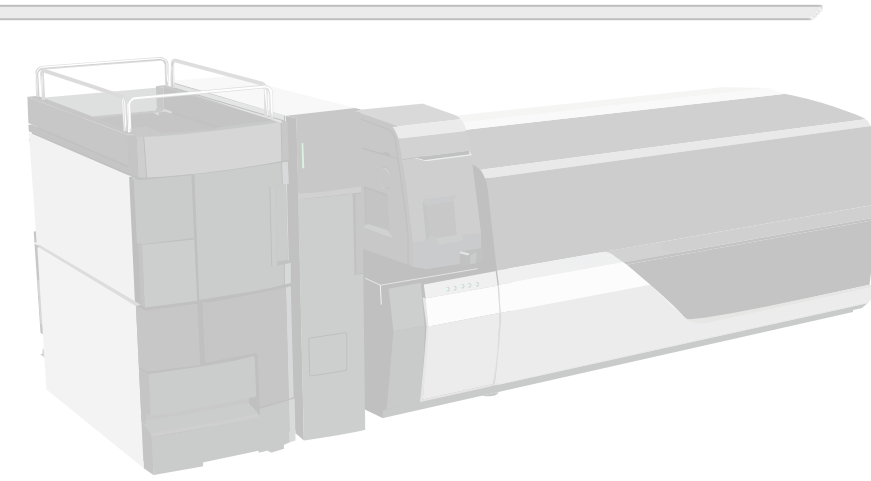

microscope

Put your data back into a broader (biologically relevant) context!

macroscope

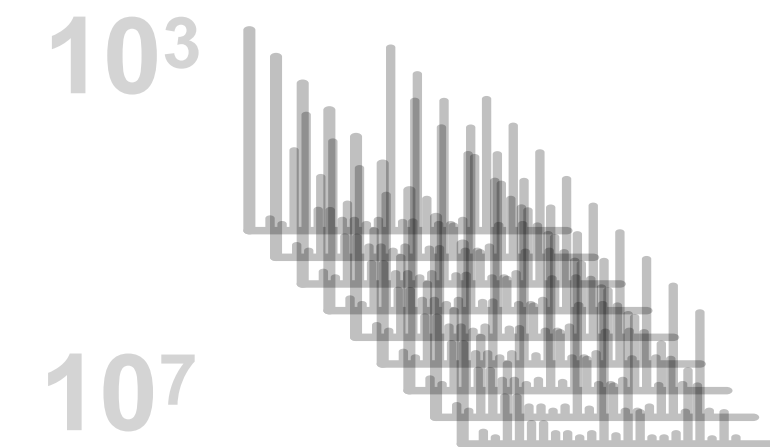

WIKIDATA

WIKIPATHWAYS
Pathways for the People

PubChem

GNPS
MASST

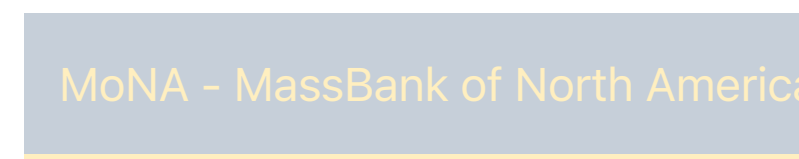
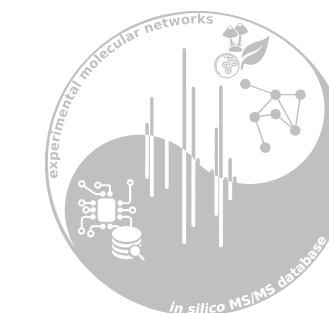

Taxonomically informed metabolite annotation

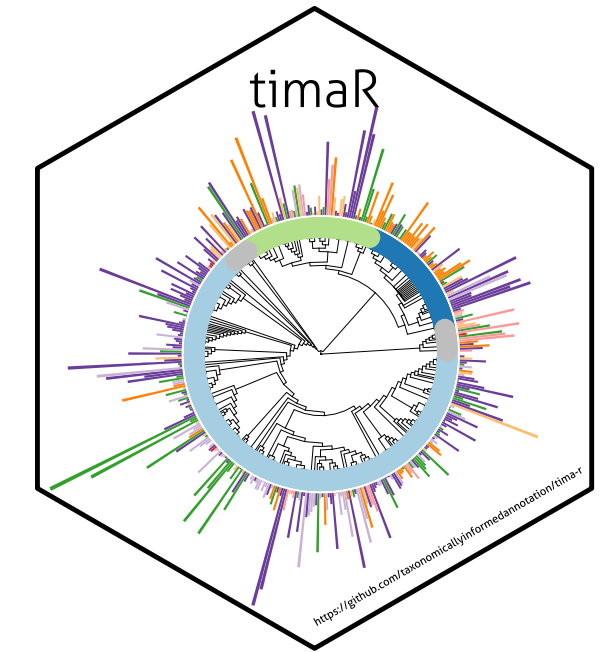

“Plant taxonomy would be the most useful guide to man in his search for new industrial and medicinal plants” (de Candolle, 1804)

Taxonomically informed metabolite annotation

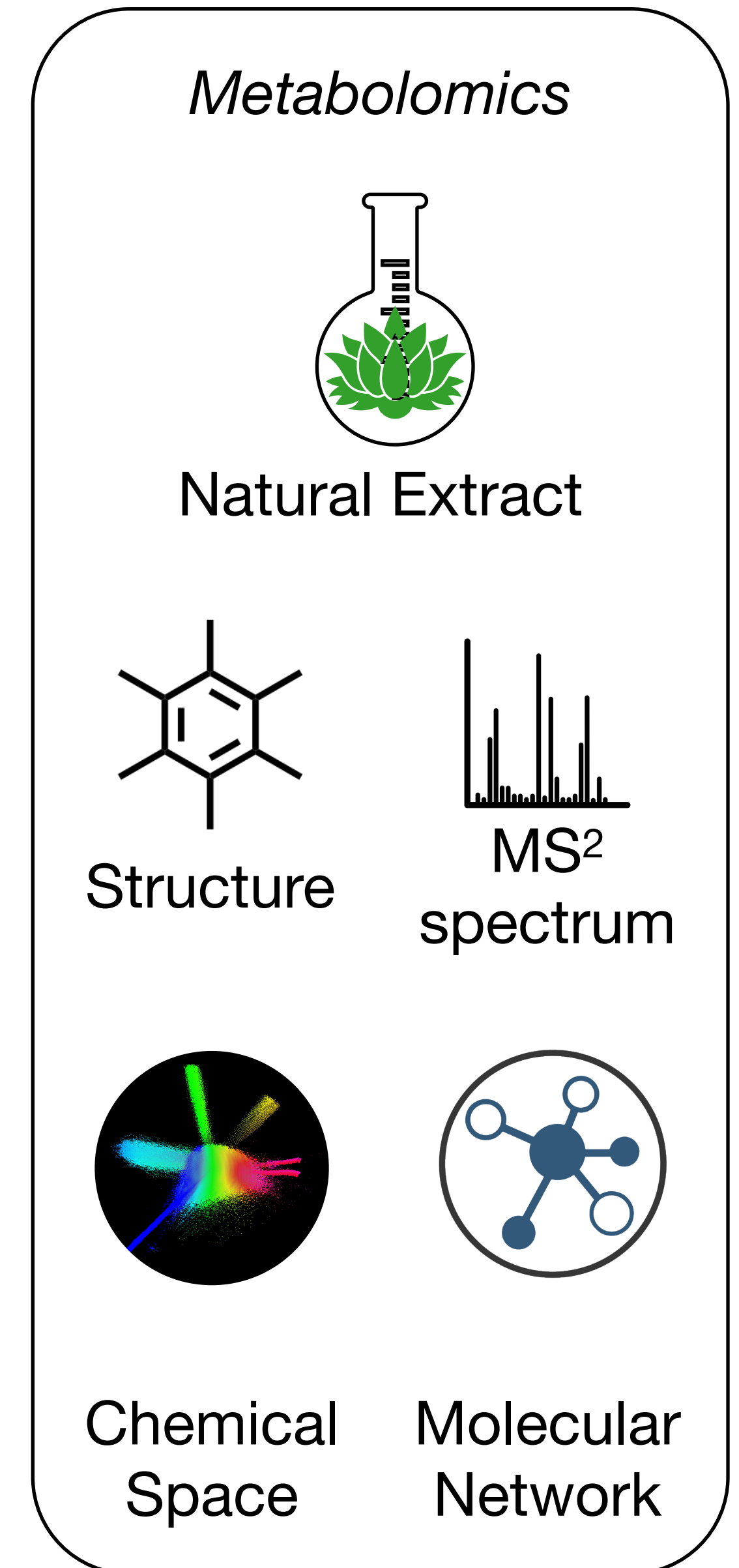

Taxonomy



Biological organism

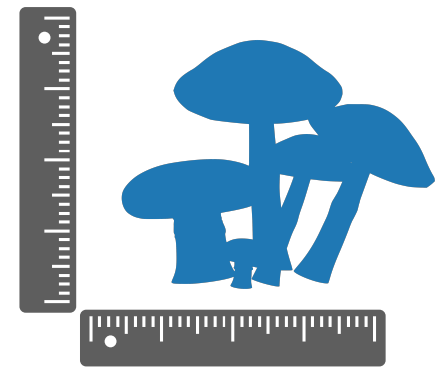

Morphological traits

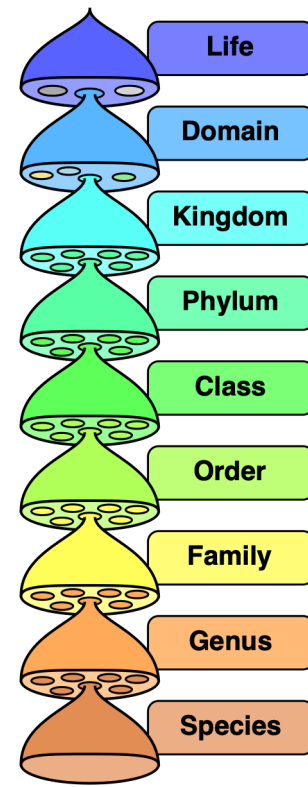

Taxonomy

Metabolomics

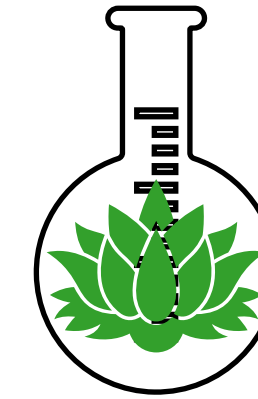

Natural Extract

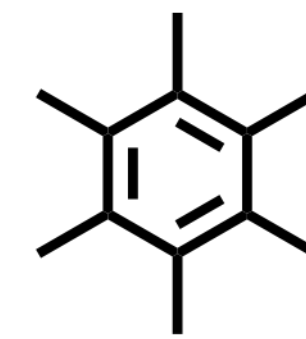

Structure

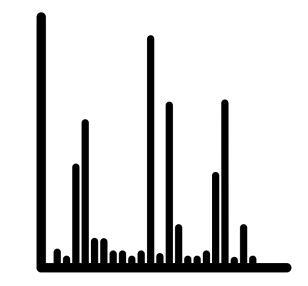

MS²
spectrum

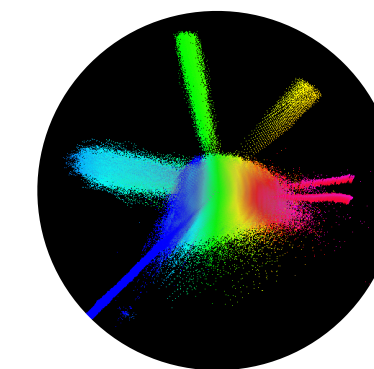

Chemical
Space

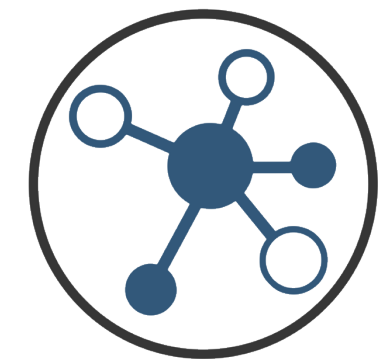

Molecular
Network

Taxonomy



Biological organism

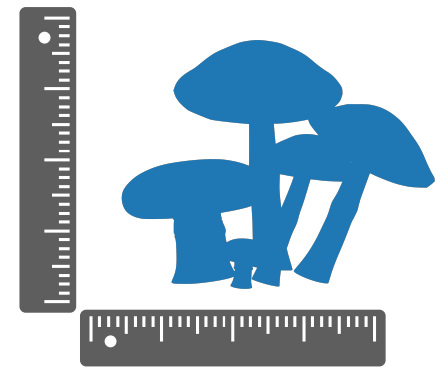

Morphological traits

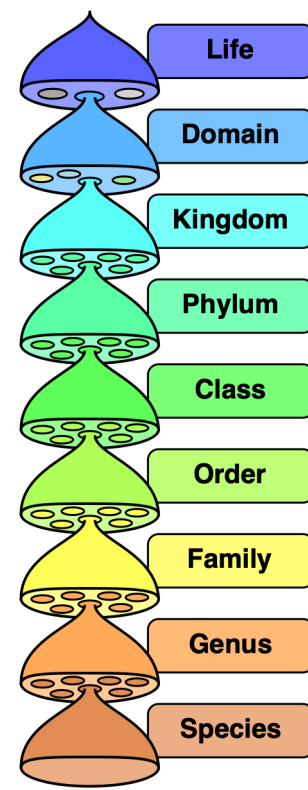

Taxonomy

Genomics



Genetic material

A T G C A A G C T T A
C G T A C C T A G G C

DNA sequence

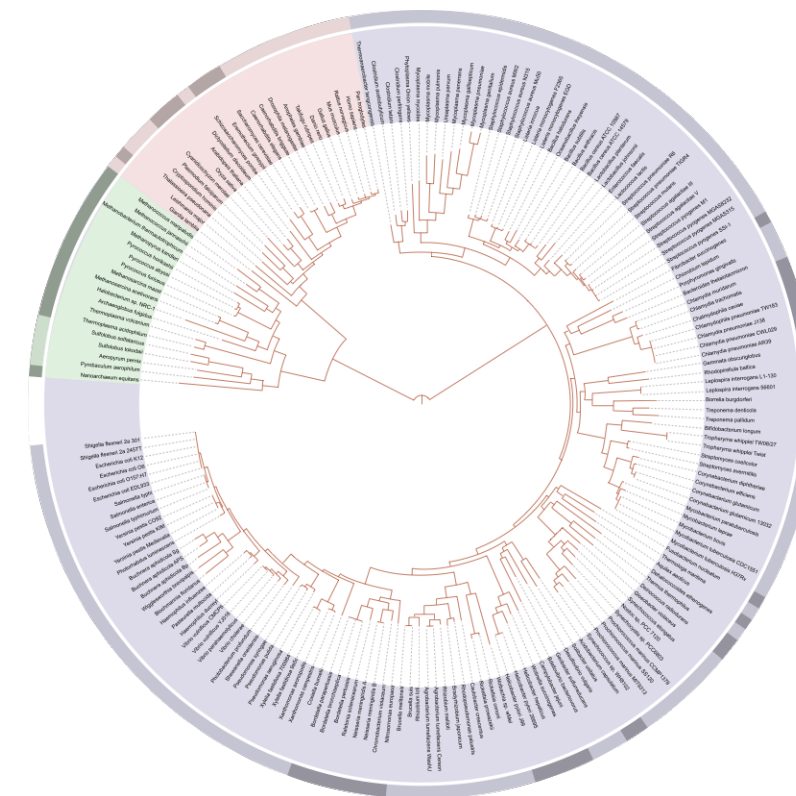

Phylogeny

Metabolomics

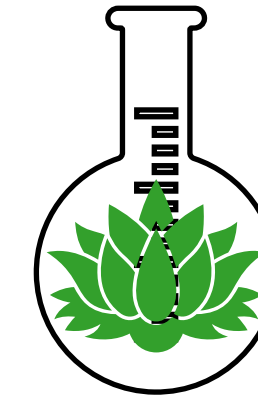

Natural Extract

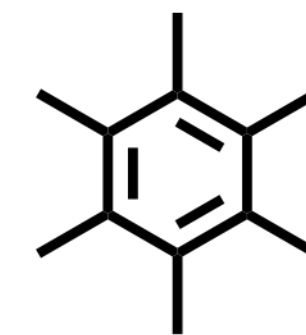

Structure

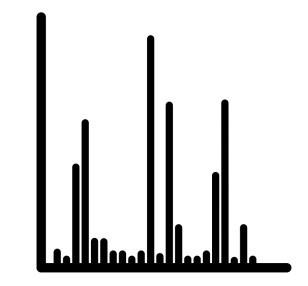

MS²
spectrum

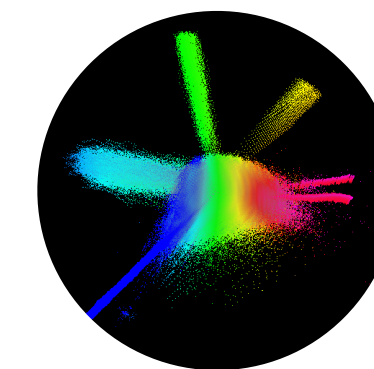

Chemical
Space

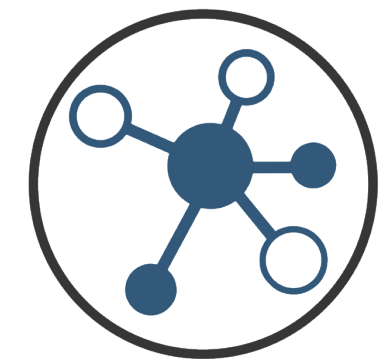

Molecular
Network

Taxonomically informed metabolite annotation

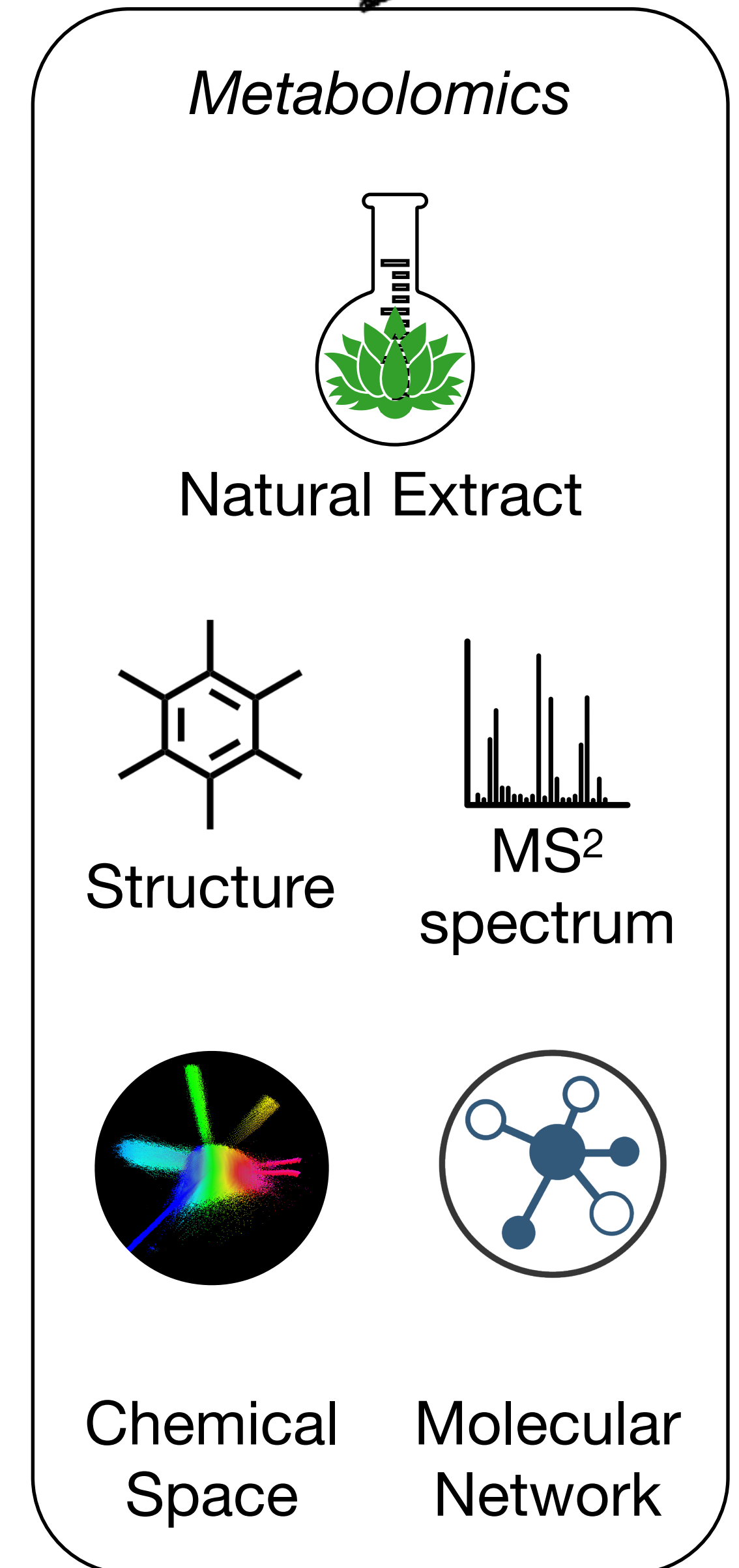
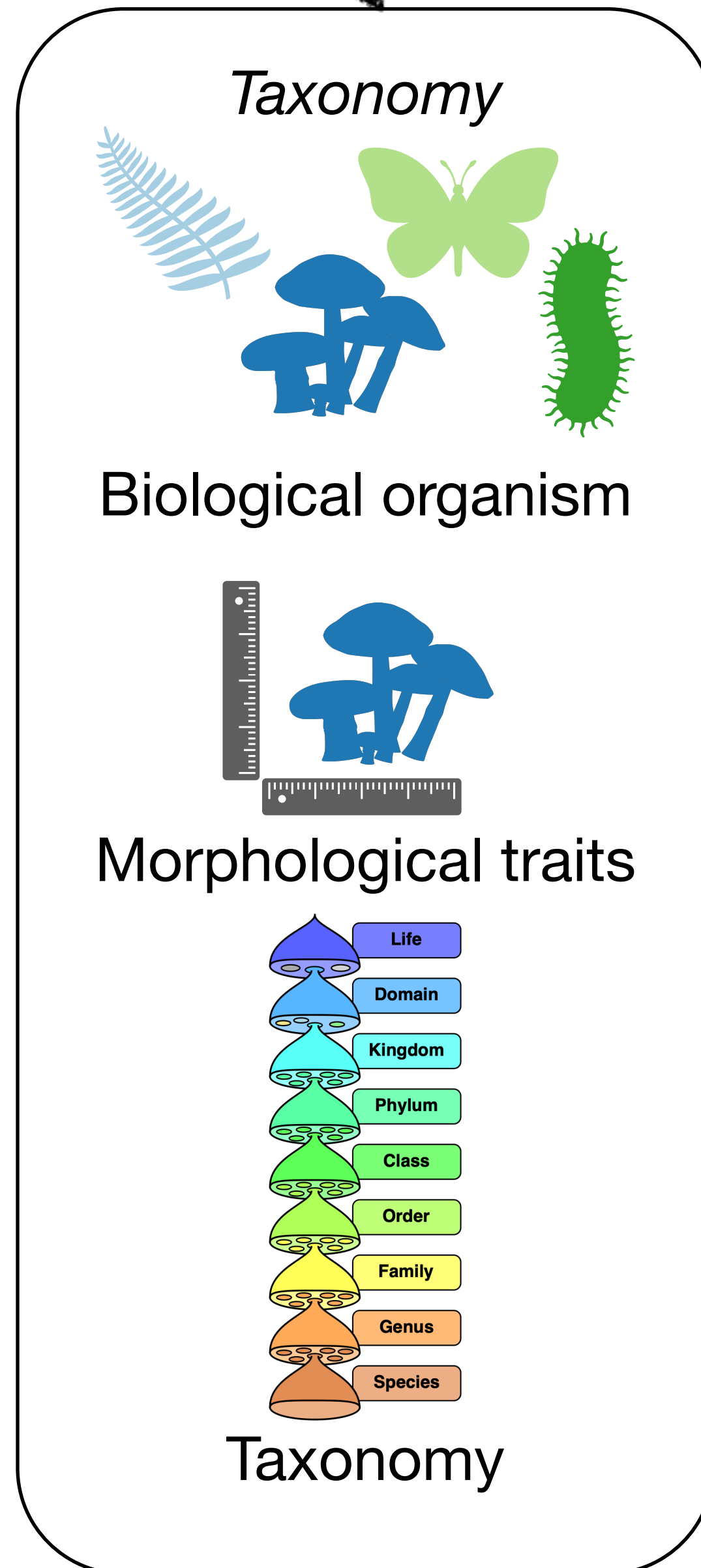

For more: <https://doi.org/10.7554/eLife.70780>

The initiative

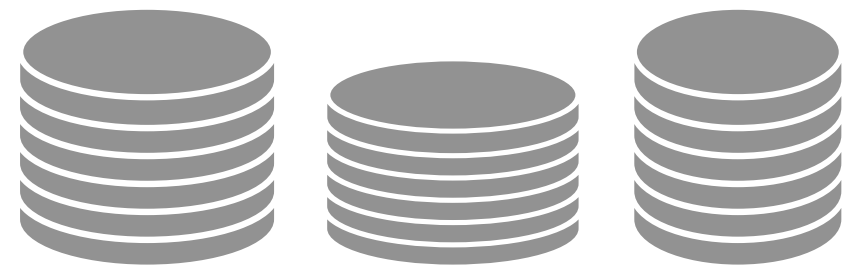

Available Natural
Product Data



LOTUS

The initiative



Available Natural
Product Data

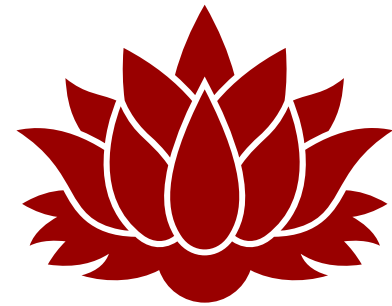

Biological
Taxon



Reference

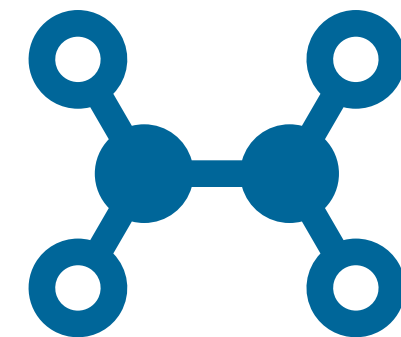

Chemical
Structure

The initiative



Available Natural
Product Data

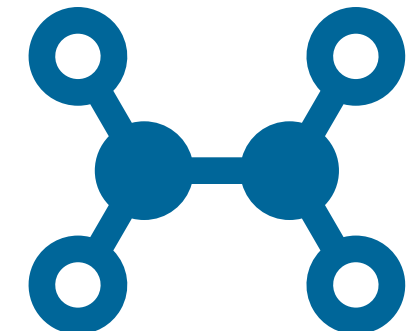

Biological
Taxon

Reference

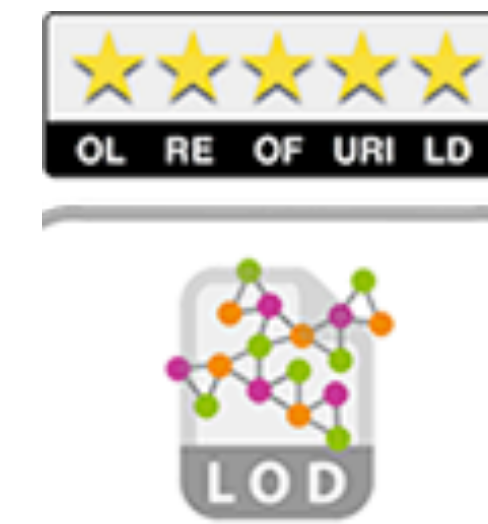

Chemical
Structure



The initiative - Wikidata

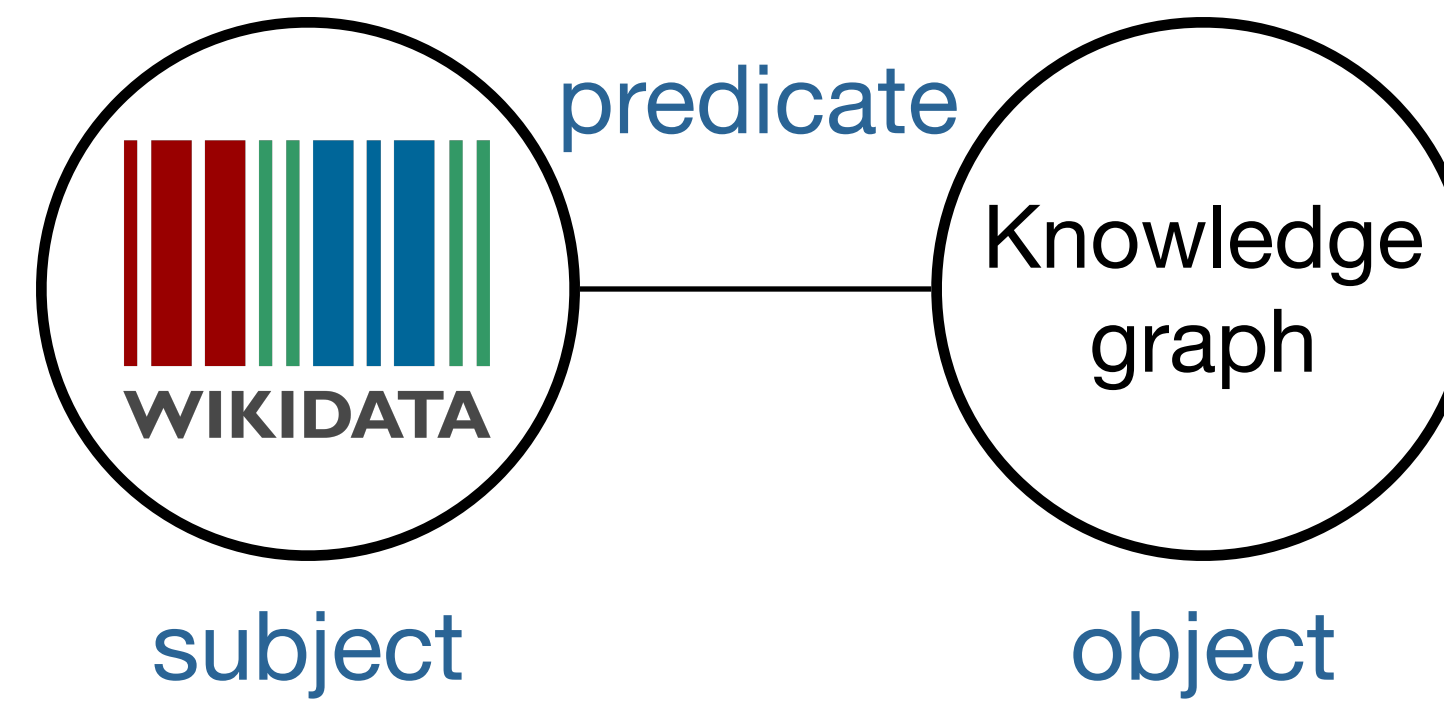

The initiative - Wikidata



The initiative - Wikidata

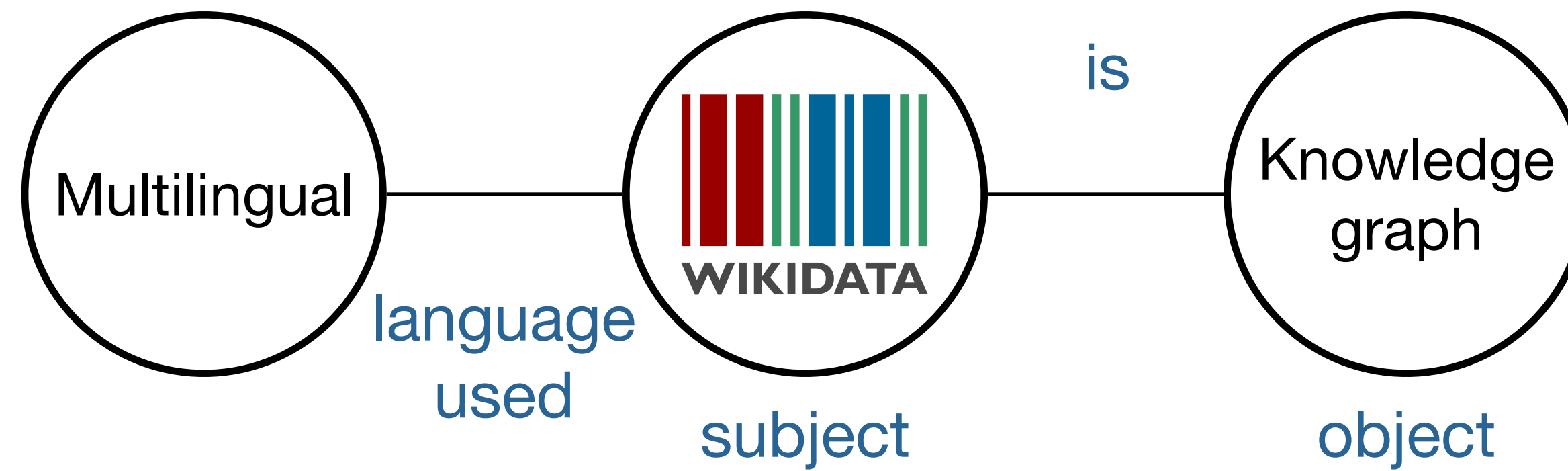

The initiative - Wikidata

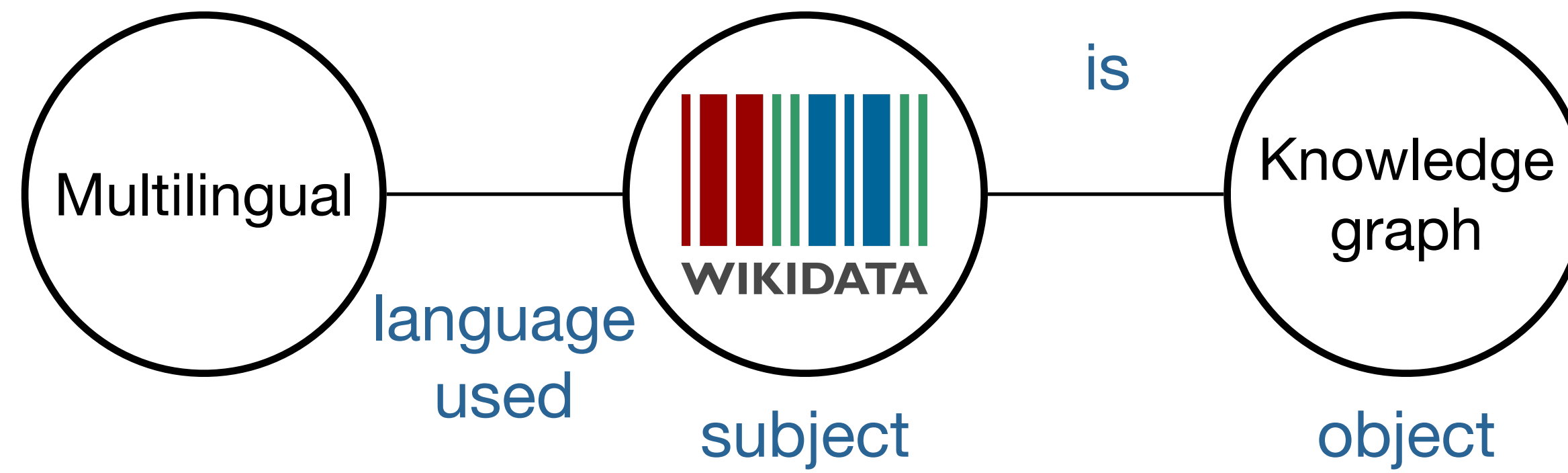

The initiative - Wikidata

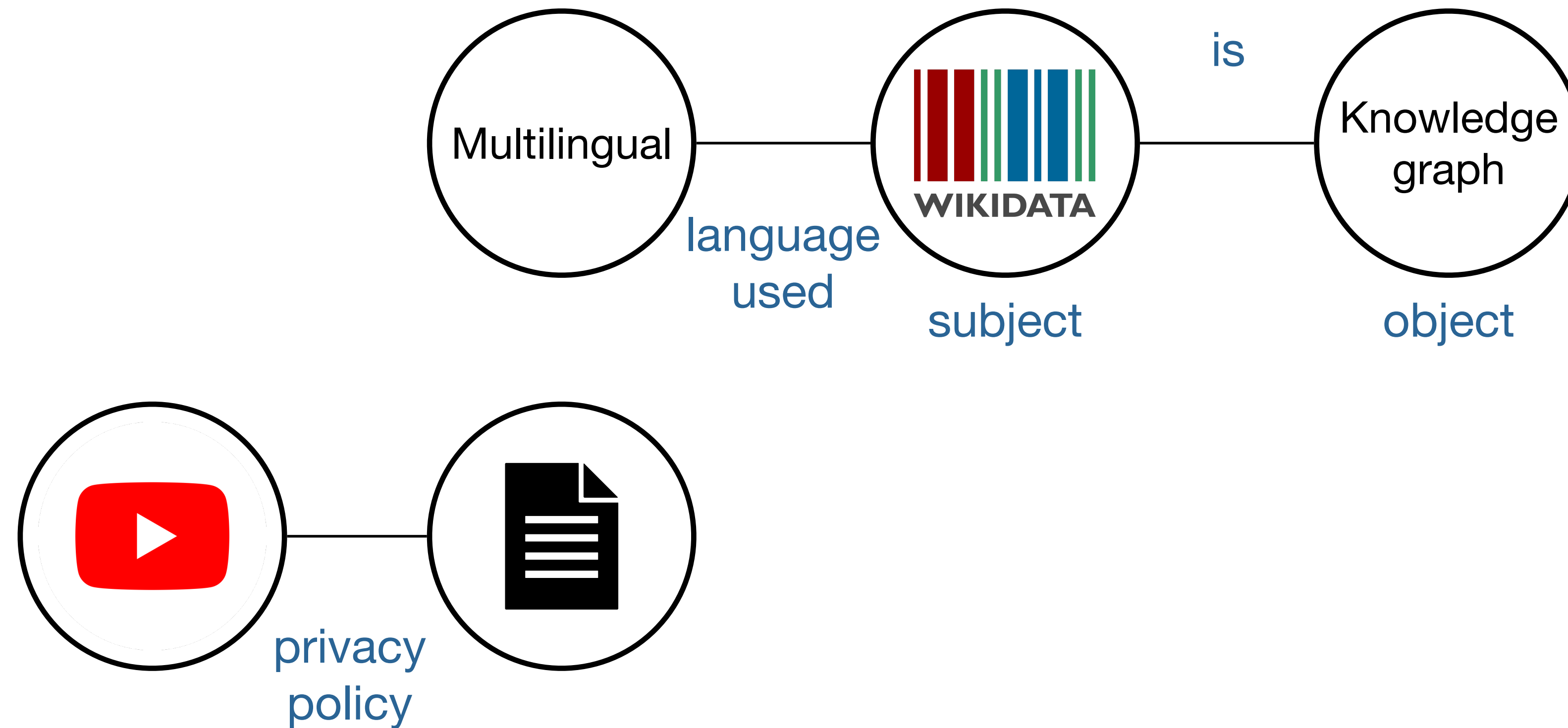

The initiative - Wikidata

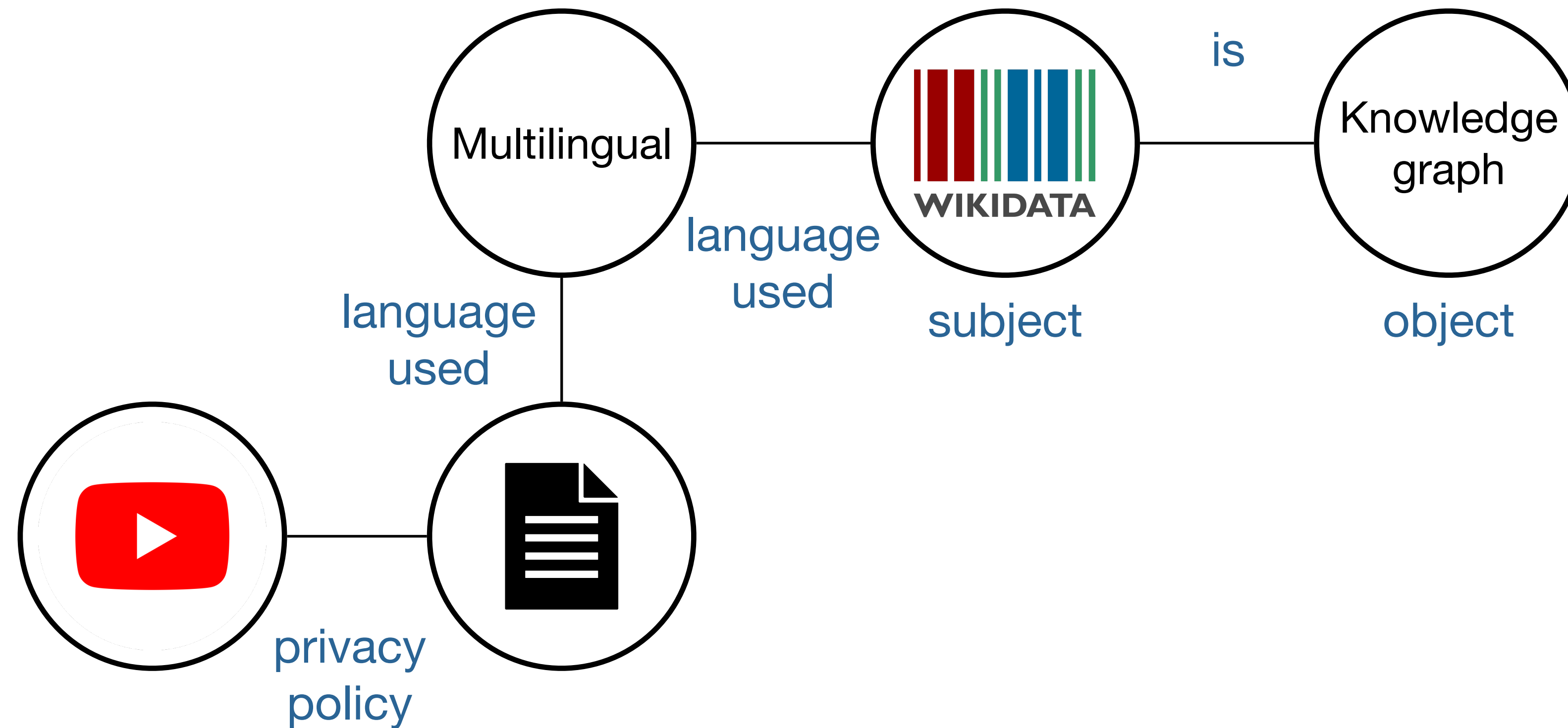

The initiative - Wikidata

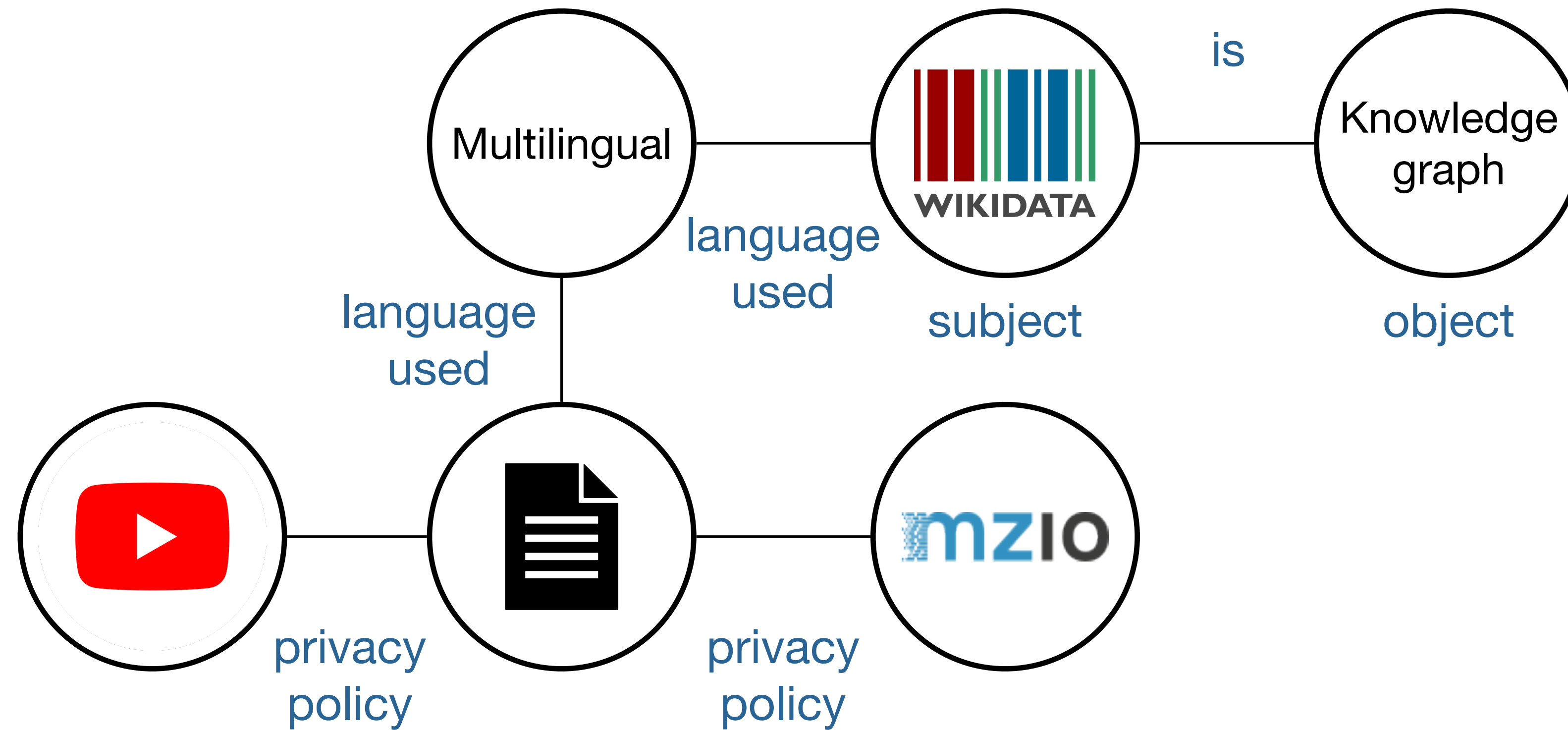

The initiative - SPARQL

« *Hey Wiki, what are the compounds found in Piper nigrum L.? »* »

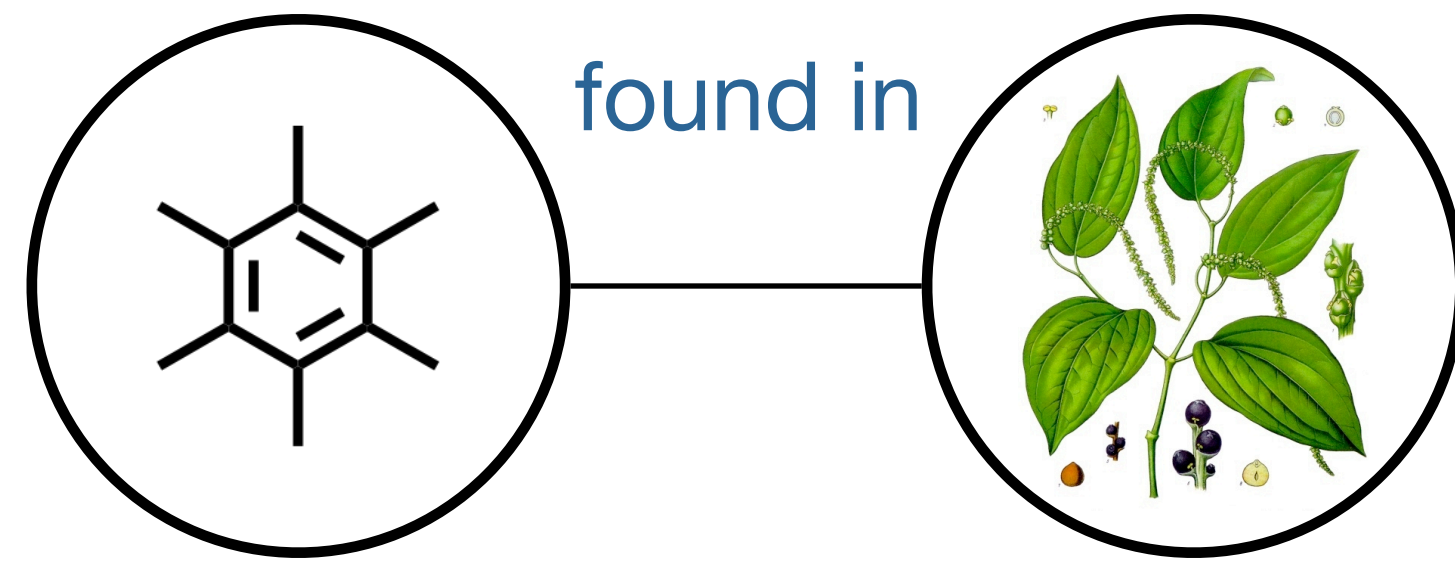

The initiative - SPARQL

« Hey Wiki, what are the compounds found in *Piper nigrum* L.? »

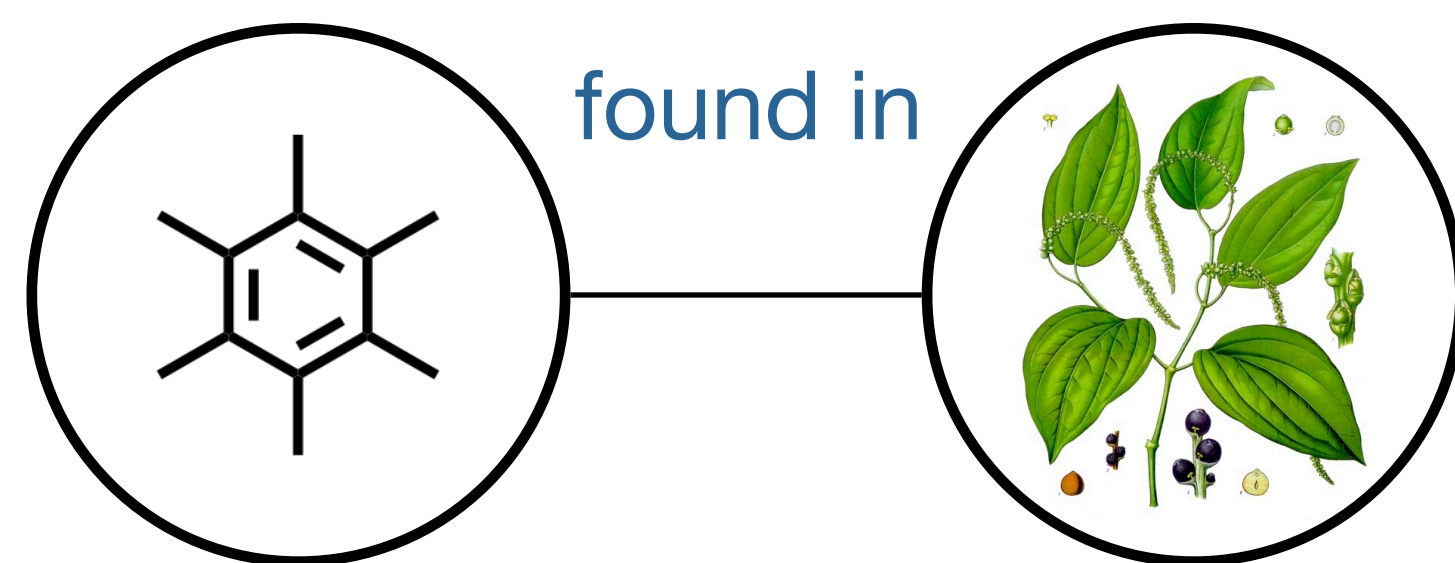

```
SELECT DISTINCT
?structure ?structure_smiles ?structure_inchikey
WHERE {
  VALUES ?organism {
    wd:Q43084 # Piper nigrum
  }
  ?organism_child (wdt:P171*) ?organism.
  ?structure wdt:P233 ?structure_smiles;
    wdt:P235 ?structure_inchikey;
    (p:P703/ps:P703) ?organism_child.
}
```

The initiative - SPARQL

« Hey Wiki, what are the compounds found in *Piper nigrum* L.? »

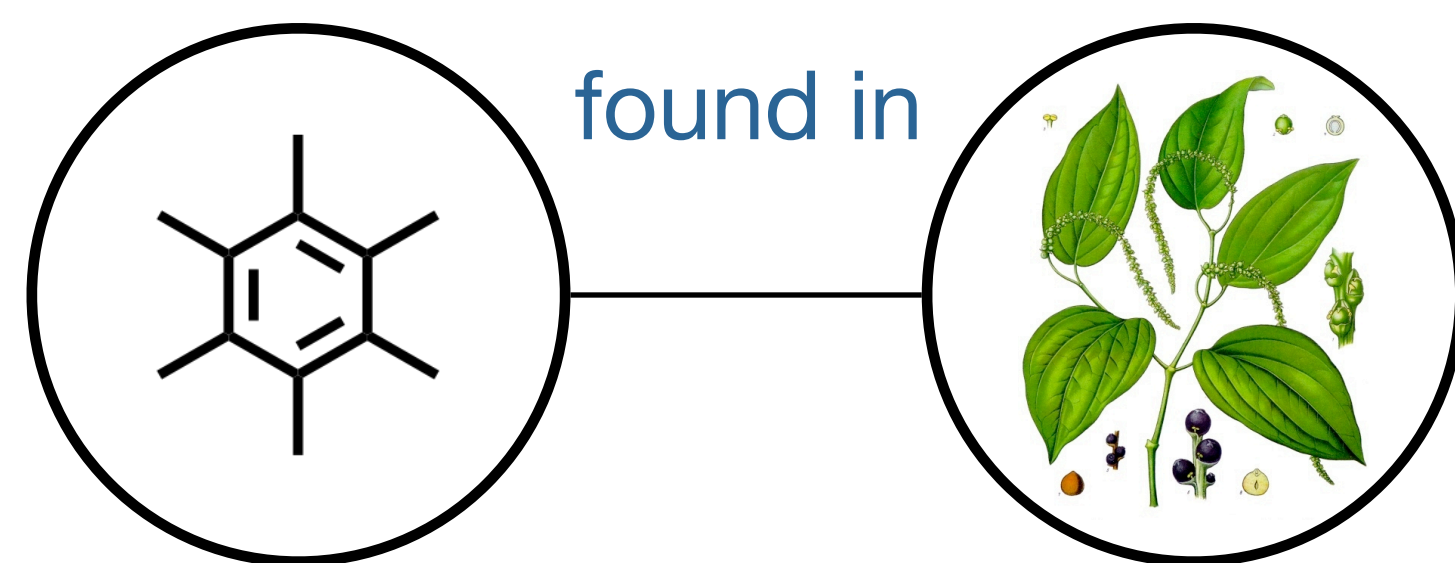

```
SELECT DISTINCT
?structure ?structure_smiles ?structure_inchikey
WHERE {
  VALUES ?organism {
    wd:Q43084 # Piper nigrum
  }
  ?organism_child (wdt:P171*) ?organism.
  ?structure wdt:P233 ?structure_smiles;
  wdt:P235 ?structure_inchikey;
  (p:P703/ps:P703) ?organism_child.
}
```

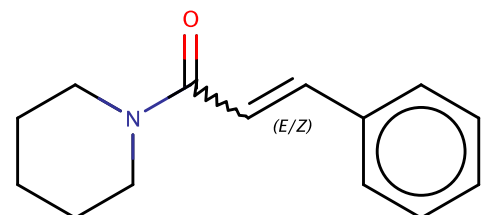
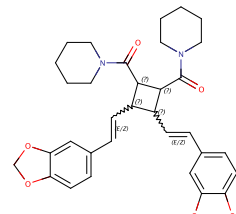
row	structure	structure_smiles	structure_inchikey
1	wd:Q105143500		KNOXUMZPTHELAO-UHFFFAOYSA-N
...
419	wd:Q105224845		QOESZPJYTVEXNN-UHFFFAOYSA-N

419 results in 0.5 second

The initiative - SPARQL

« Hey Wiki, what are the compounds found in *Piper nigrum* L.? »

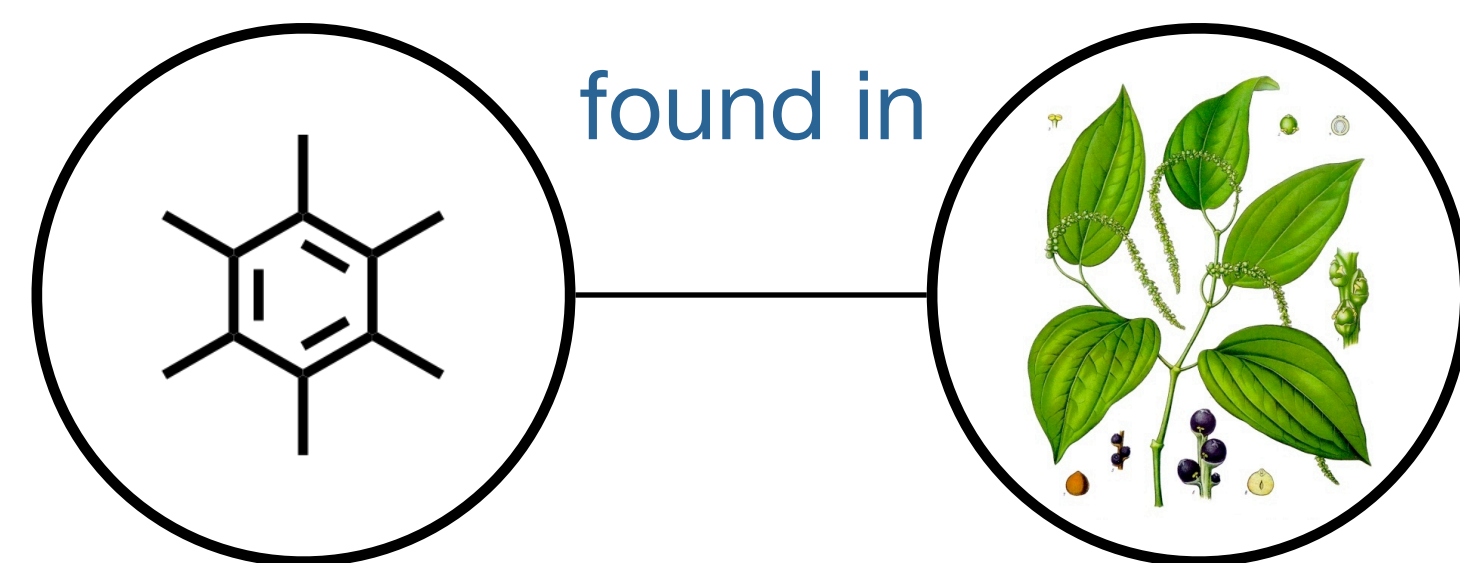

```
SELECT DISTINCT
?structure ?structure_smiles ?structure_inchikey
WHERE {
  VALUES ?organism {
    wd:Q43084 # Piper nigrum
  }
  ?organism_child (wdt:P171*) ?organism.
  ?structure wdt:P233 ?structure_smiles;
    wdt:P235 ?structure_inchikey;
    (p:P703/ps:P703) ?organism_child.
}
```

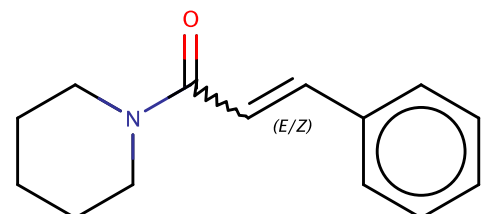
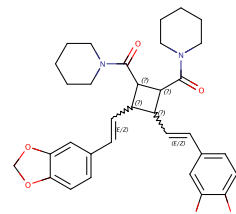

row	structure	structure_smiles	structure_inchikey
1	wd:Q105143500		KNOXUMZPTHELAO-UHFFFAOYSA-N
...
419	wd:Q105224845		QOESZPJYTVEXNN-UHFFFAOYSA-N

419 results in 0.5 second

The initiative - SPARQL

« *Hey Wiki, what are the compounds found in Ranunculaceae?* »

3,398 results in 0.9 second

The initiative - SPARQL

« *Hey Wiki, what are the compounds found in Ranunculaceae?* »

3,398 results in 0.9 second

« *Hey Wiki, what are the compounds found in Ranunculales?* »

6,350 results in 1.4 seconds

The initiative - SPARQL

« Hey Wiki, what are the compounds found in Ranunculaceae? »

3,398 results in 0.9 second

« Hey Wiki, what are the compounds found in Ranunculales? »

6,350 results in 1.4 seconds

« Sorry Wiki, I forgot, how many species belong to Ranunculales? »

11,669 results in 1.1 seconds

The initiative - SPARQL

« Hey Wiki, what are the compounds found in Ranunculaceae? »

3,398 results in 0.9 second

« Sorry Wiki, I forgot, how many species belong to Ranunculales? »

11,669 results in 1.1 seconds

« Hey Wiki, what are the compounds found in Ranunculales? »

6,350 results in 1.4 seconds

« Ok Wiki, among the compounds found in the Ranunculales how many were already described as bitter? »

59 results in 1.4 seconds



The initiative - SPARQL

« Ok Wiki, which genera contain compounds structurally similar to the ones reported as pungent in black pepper, and how many? List the top 5 only »

The initiative - SPARQL

« Ok Wiki, which genera contain compounds structurally similar to the ones reported as pungent in black pepper, and how many? List the top 5 only »

5 results in 1.1 seconds

row	taxon	taxon_name	count
1	wd:Q159536	<i>Piper</i>	35
2	wd:Q163563	<i>Zingiber</i>	31
3	wd:Q133290	<i>Syzygium</i>	4
4	wd:Q2607361	<i>Aframomum</i>	4
5	wd:Q27583	<i>Bellis</i>	3



Developed right here!

For more: <https://doi.org/10.1186/s13321-018-0282-y>



The initiative - Community curation



Item [Discussion](#) [Read](#) [View history](#)

hyperelodione D (Q116482353)

chemical compound [edit](#)

Language	Label	Description	Also known as
English	hyperelodione D	chemical compound	

Statements

instance of	chemical compound 0 references
mass	548.797 dalton 1 reference based on heuristic inferred from SMILES
chemical formula	$C_{36}H_{52}O_4$ 1 reference based on heuristic inferred from SMILES

- Main page
- Community portal
- Project chat
- Create a new Item
- Recent changes
- Random Item
- Query Service
- Nearby
- Help
- Donate
- Lexicographical data
- Create a new Lexeme
- Recent changes
- Random Lexeme
- Tools
- What links here
- Related changes
- Special pages
- Permanent link
- Page information
- Concept URI
- Cite this page

English Not logged in Talk Contributions Create account Log in

The initiative - Community curation



Item [Discussion](#) [Read](#) [View history](#)

hyperelodione D (Q116482353)

chemical compound [edit](#)

Language	Label	Description	Also known as
English	hyperelodione D	chemical compound	

canonical SMILES

C/C(C)=C\CC/C(C)=C/CC1=C2C3(O[H])C(C4(C/C=C(C)/CC/C=C(C)/C/C)C1=O)(O[H])C(C(C)=CC4)([H])CC3([H])C(C)(C)O2

[reason for deprecated rank](#) [structural reassignment](#)

1 reference

[stated in](#) [Cytotoxic polyprenylated phloroglucinol derivatives from Hypericum elodeoides Choisy modulating the transactivation of RXRα](#)

C/C(C)=C/CC1=C2C3(O[H])C(C4(C/C=C(C)/CC/C=C(C)/C)C1=O)(O[H])C(C(C)=CC4)([H])CC3([H])C(CC/C=C(C)/C)(C)O2

[reason for preferred rank](#) [structural reassignment](#)

1 reference

[stated in](#) [Bioinspired Total Synthesis of Erectones A and B, and the Revised Structure of Hyperelodione D](#)

The initiative - back to annotations

« *But Wiki, can this help me with my annotations?* »

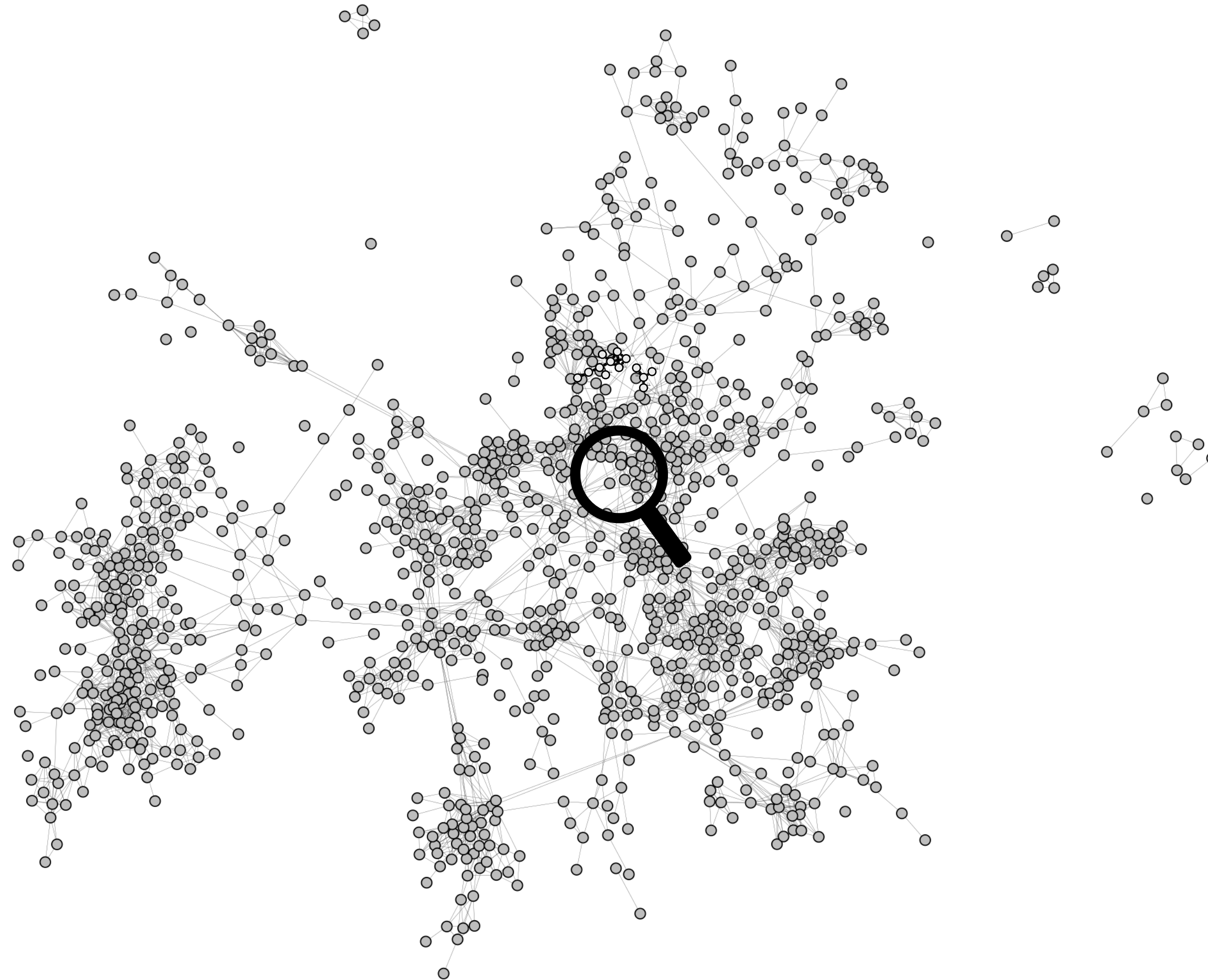

The initiative - back to annotations

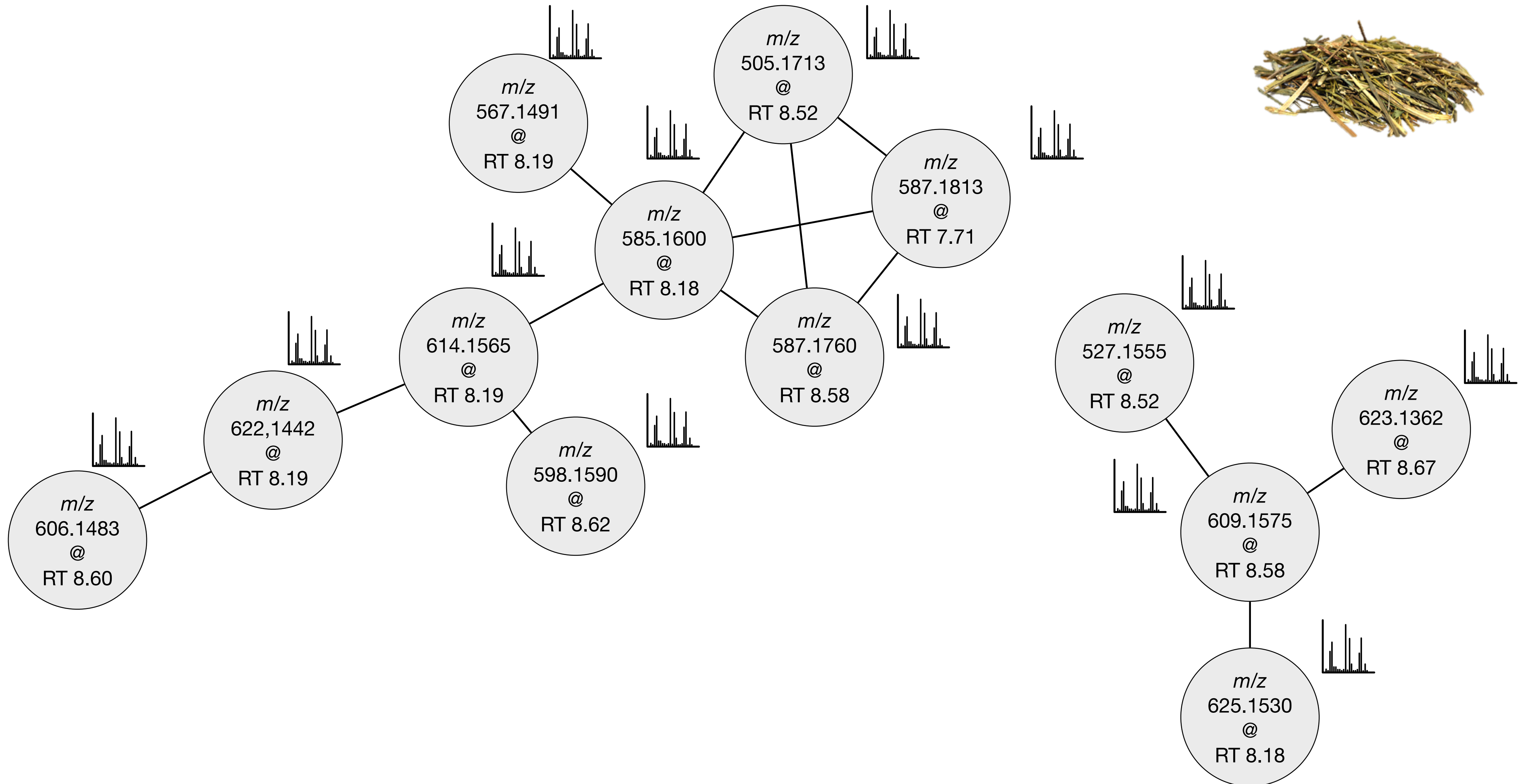

 **GNPS**
(experimental)

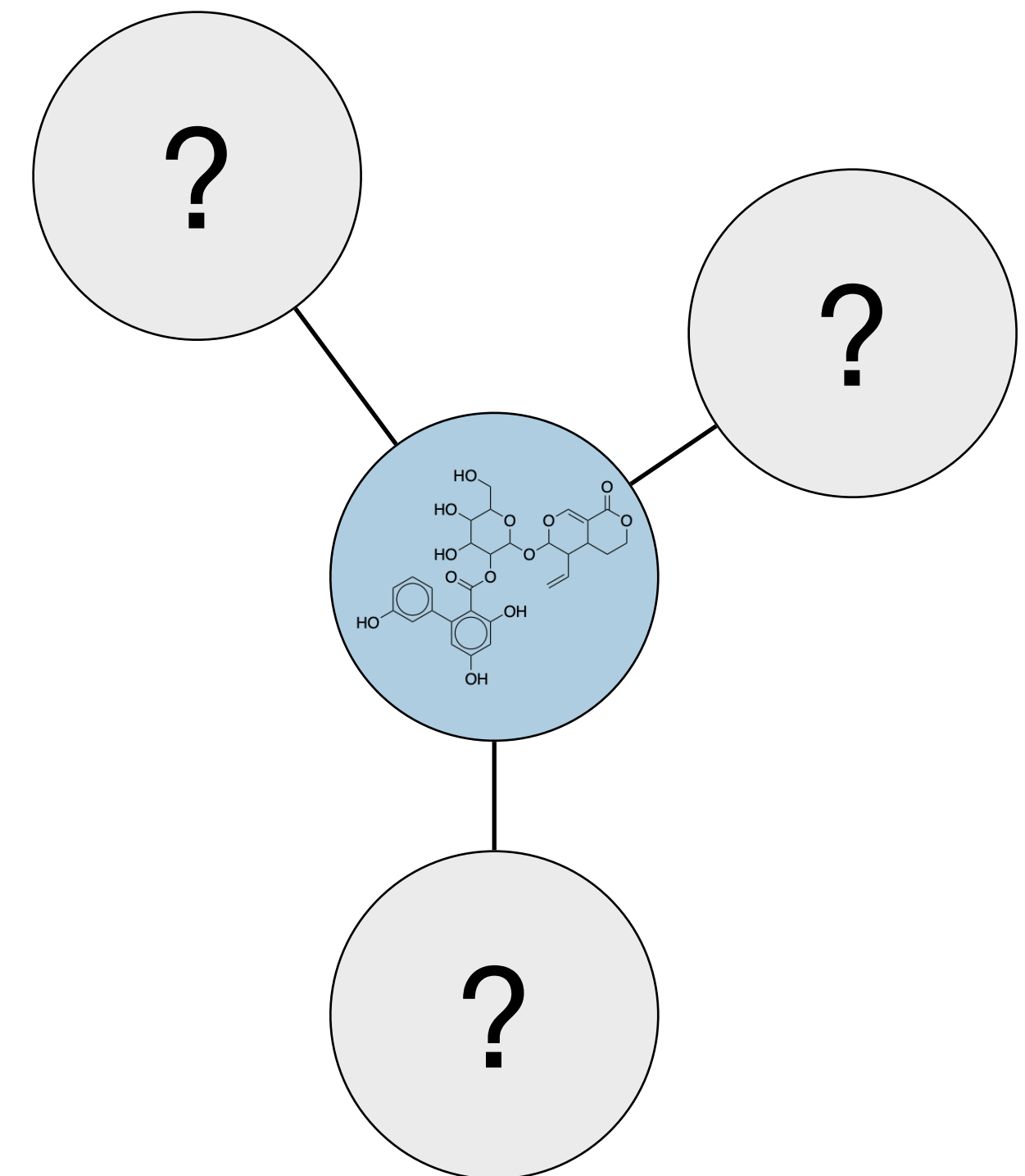
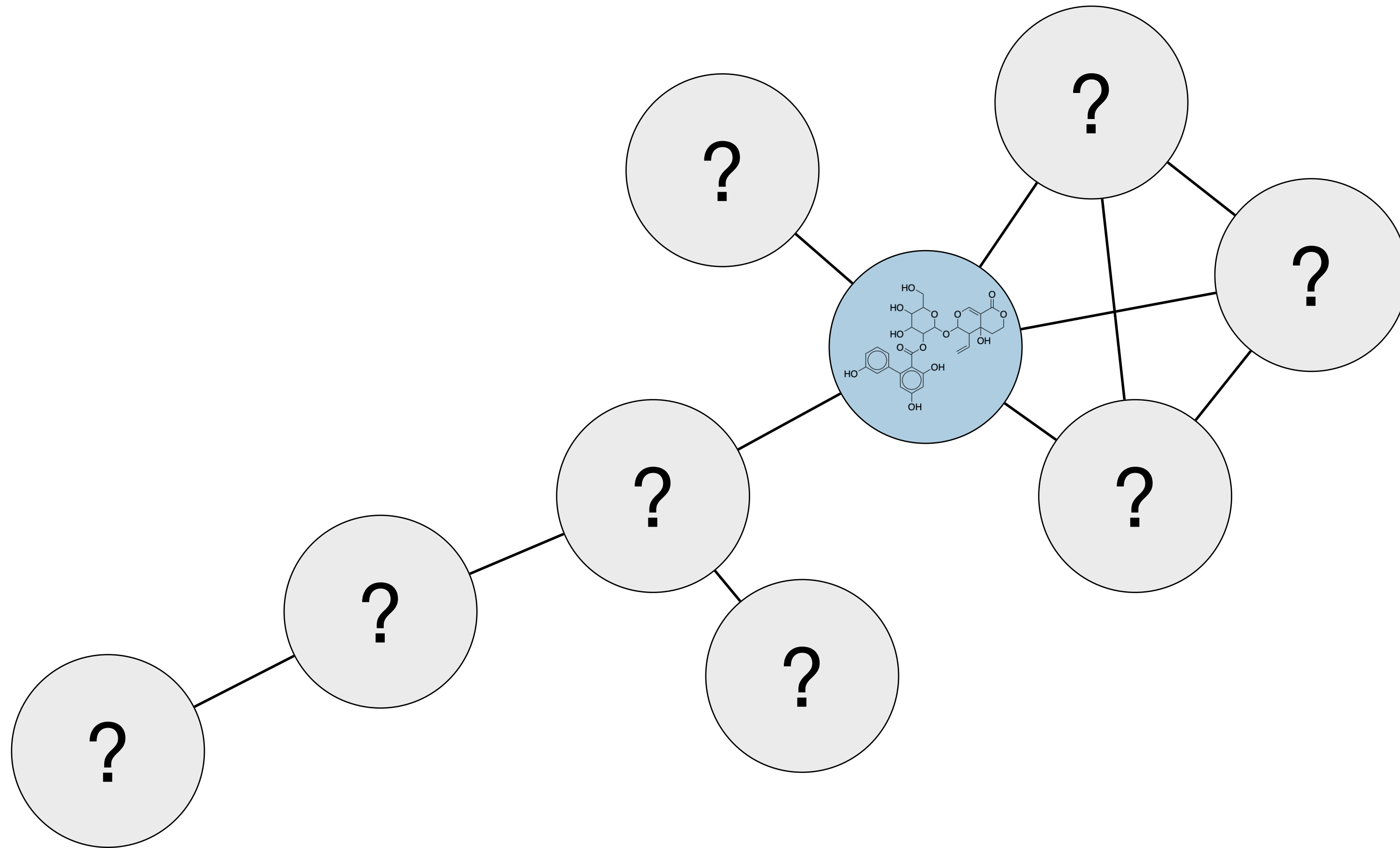

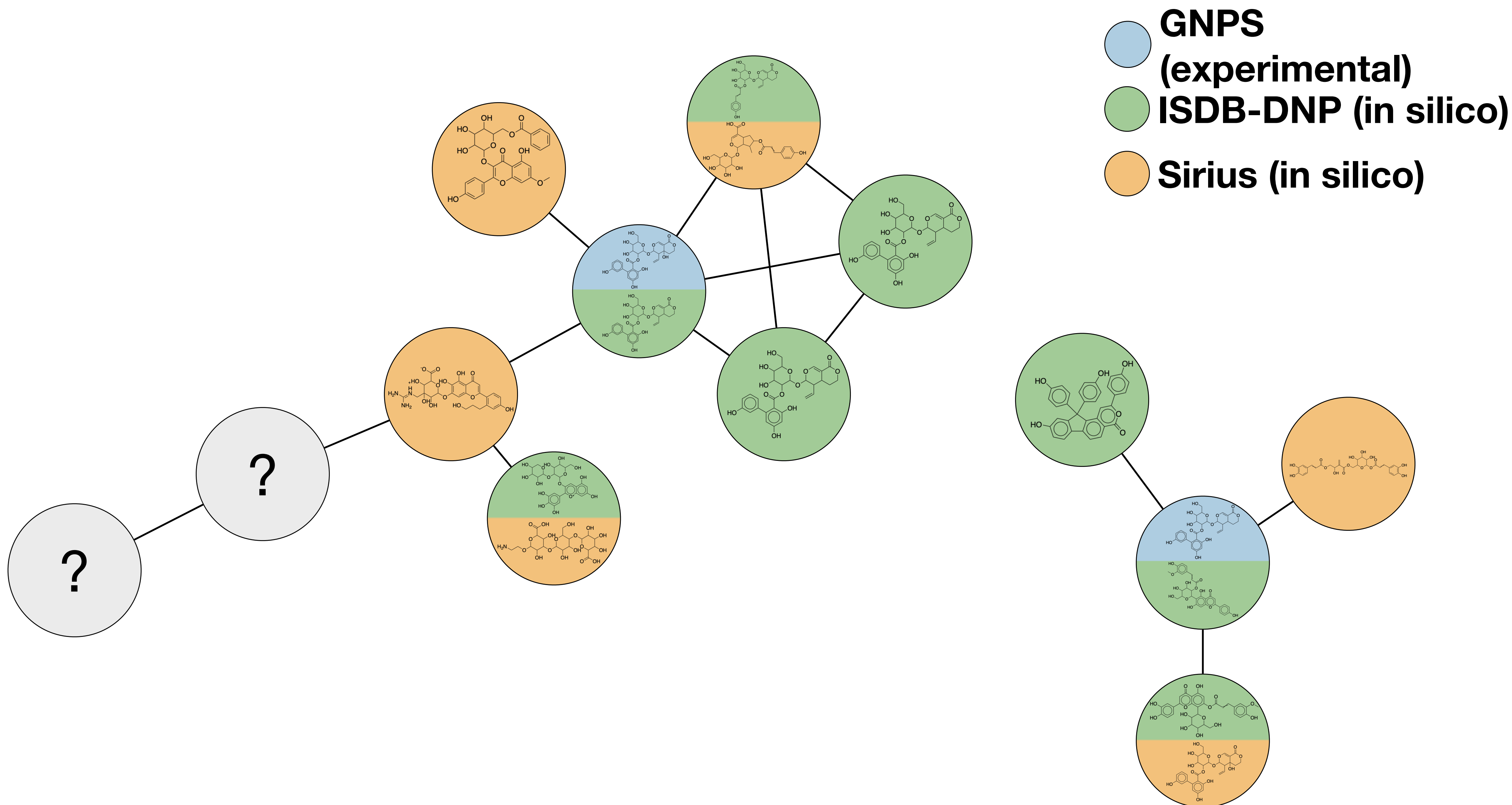

LOD-based annotation

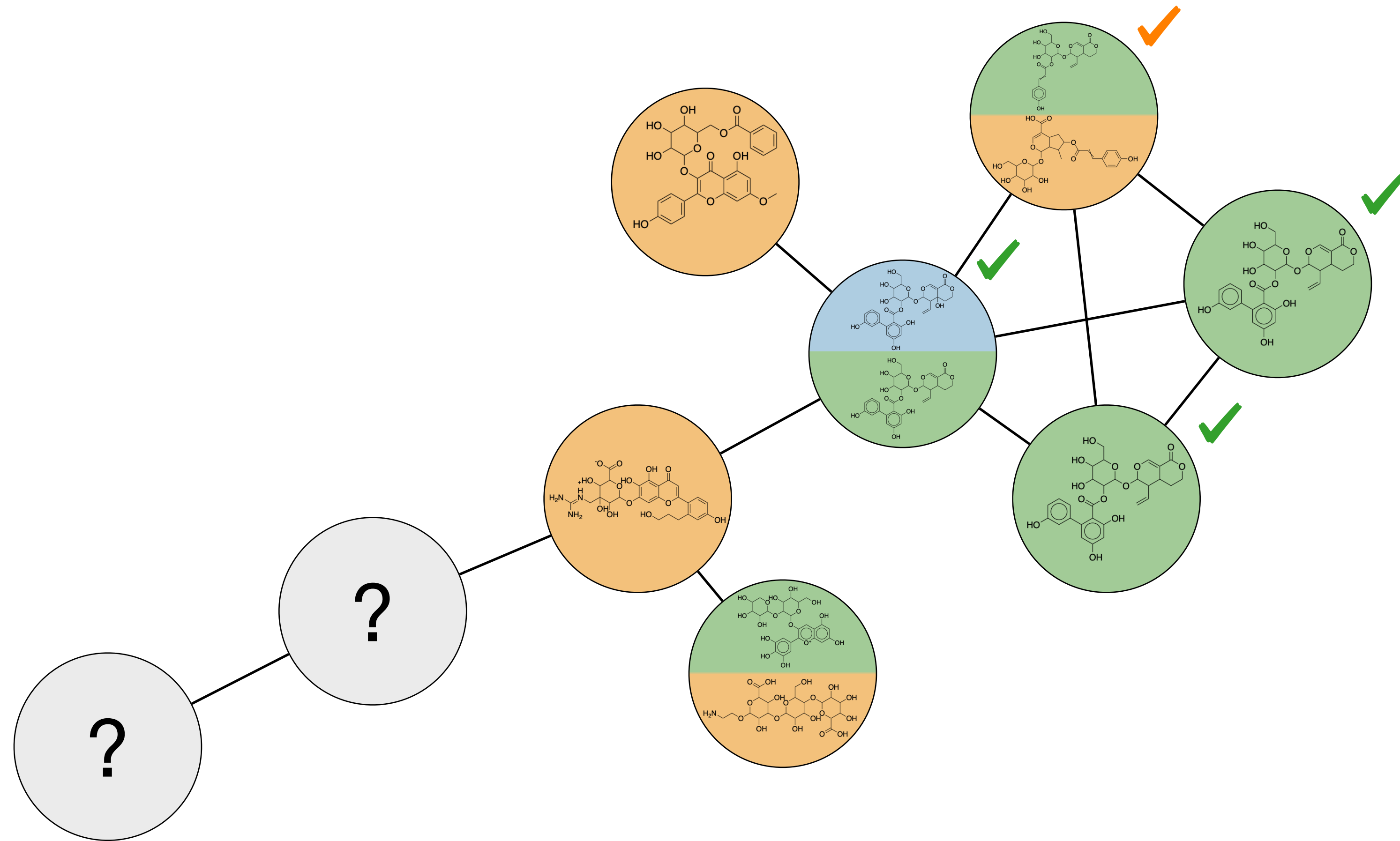

- GNPS (experimental)
- ISDB-DNP (in silico)
- Sirius (in silico)
- ✓ Found in the genus
- ✓ Found in the family

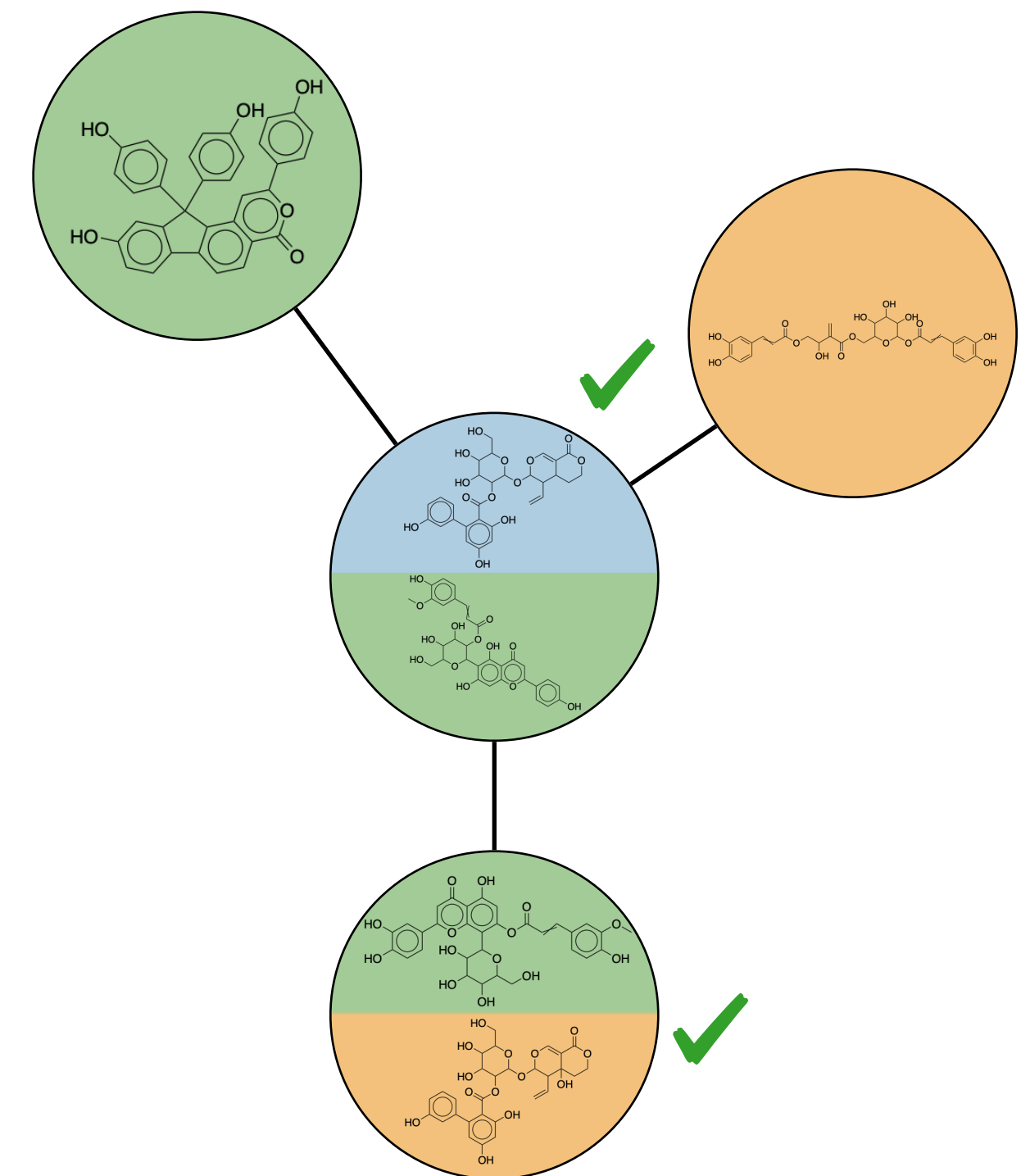

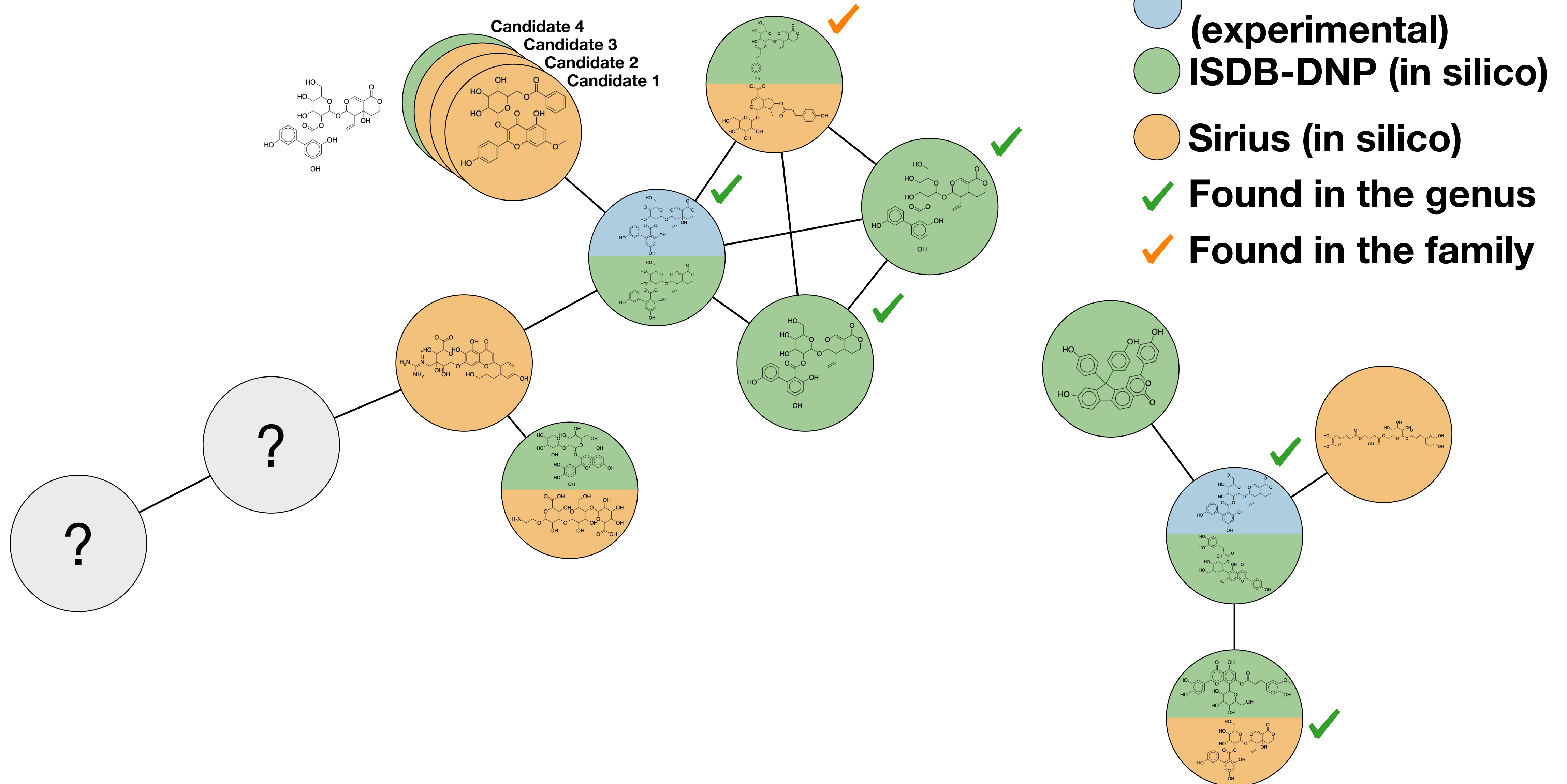

LOD-based annotation

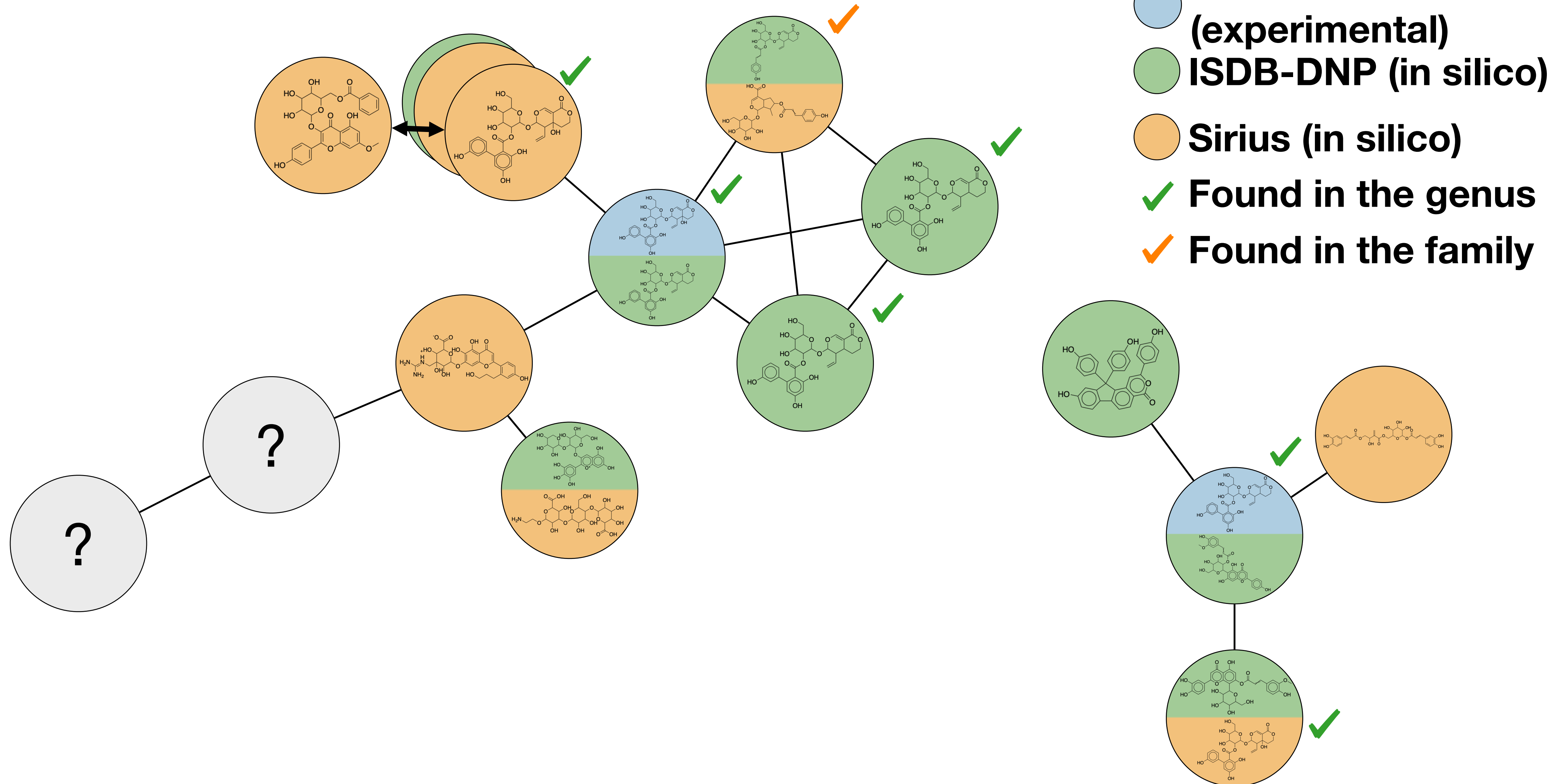

LOD-based annotation

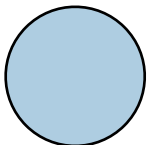
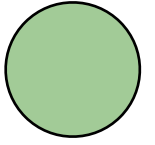
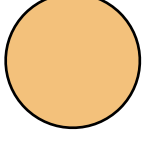

LOD-based annotation

-  **GNPS (experimental)**
-  **ISDB-DNP (in silico)**
-  **Sirius (in silico)**
-  **Found in the genus**
-  **Found in the family**

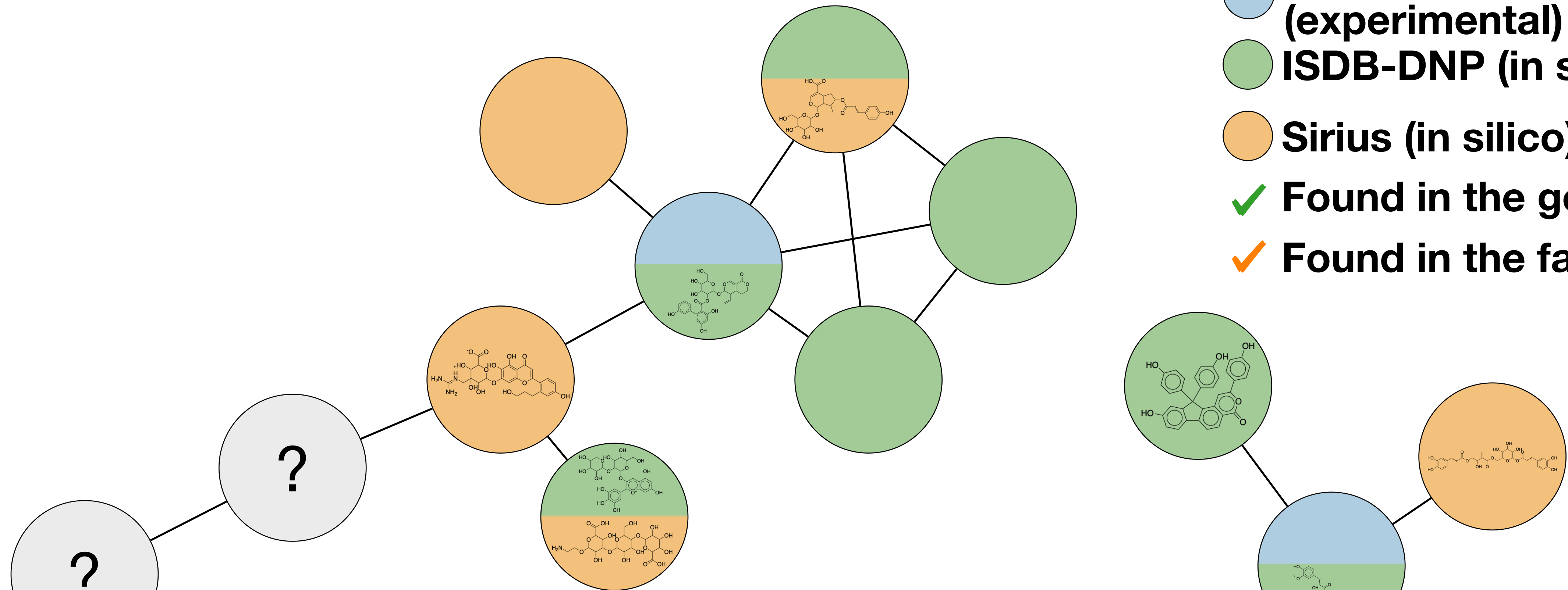

Secoiridoid monoterpenoids

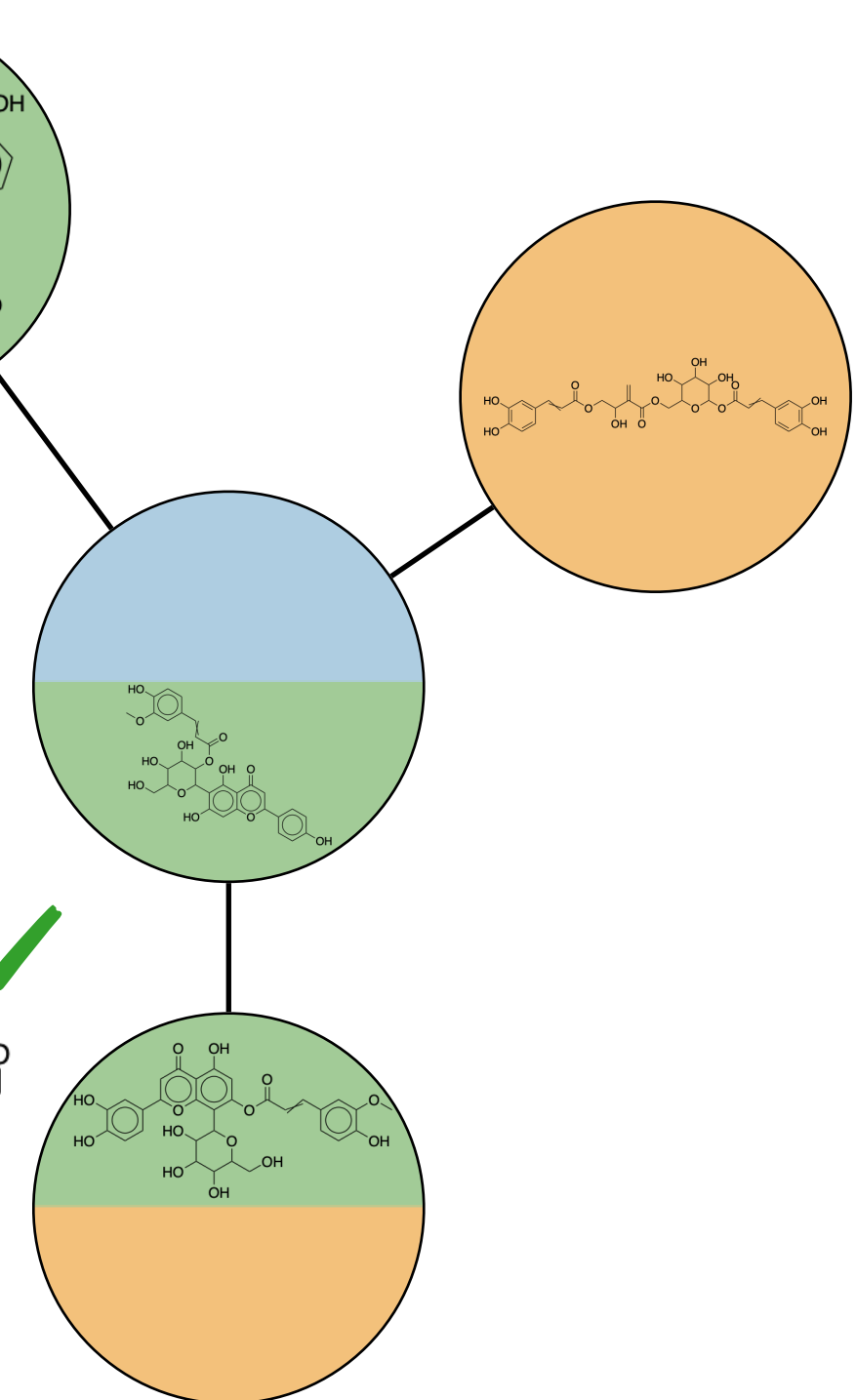
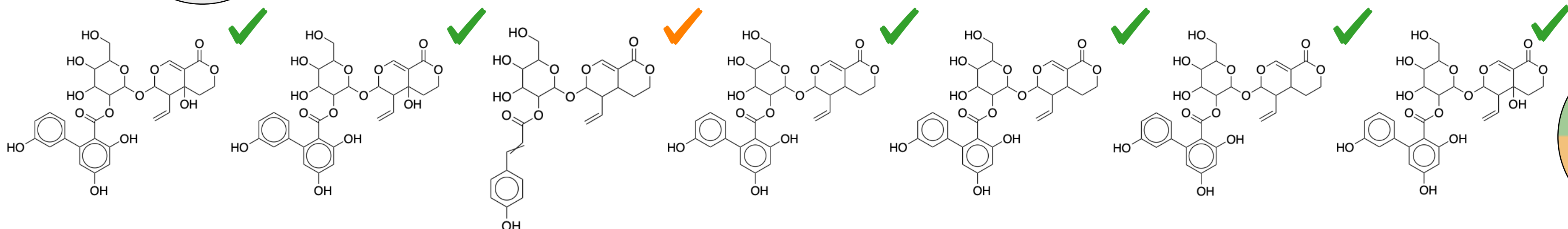

LOD-based annotation

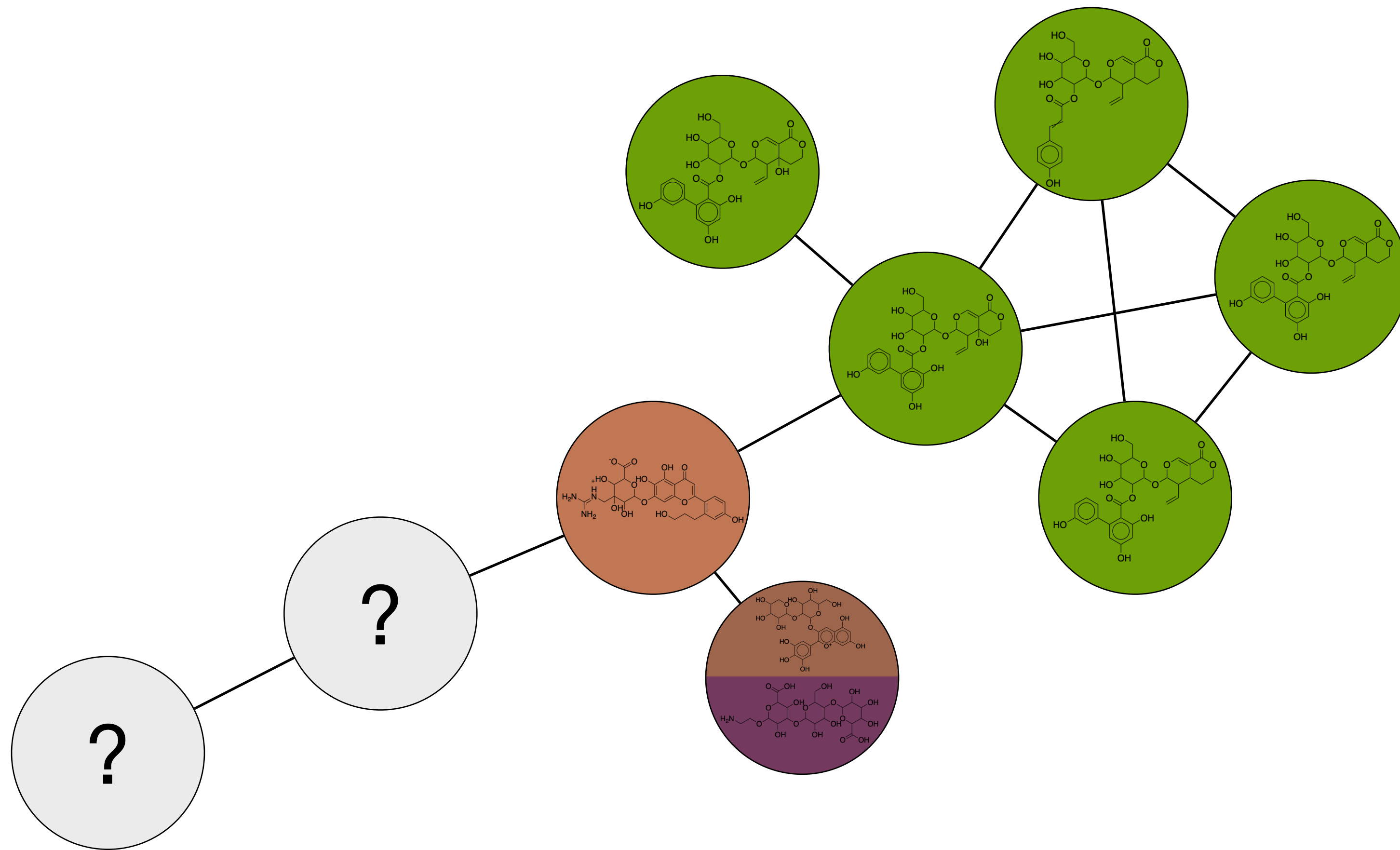

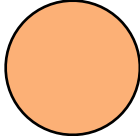
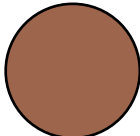
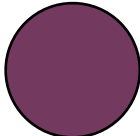
-  **Secoiridoid monoterpeneoids**
-  **Cinnamic acids and derivative**
-  **Selaginellins**
-  **Flavones**
-  **Anthocyanidins**
-  **Polysaccharides**

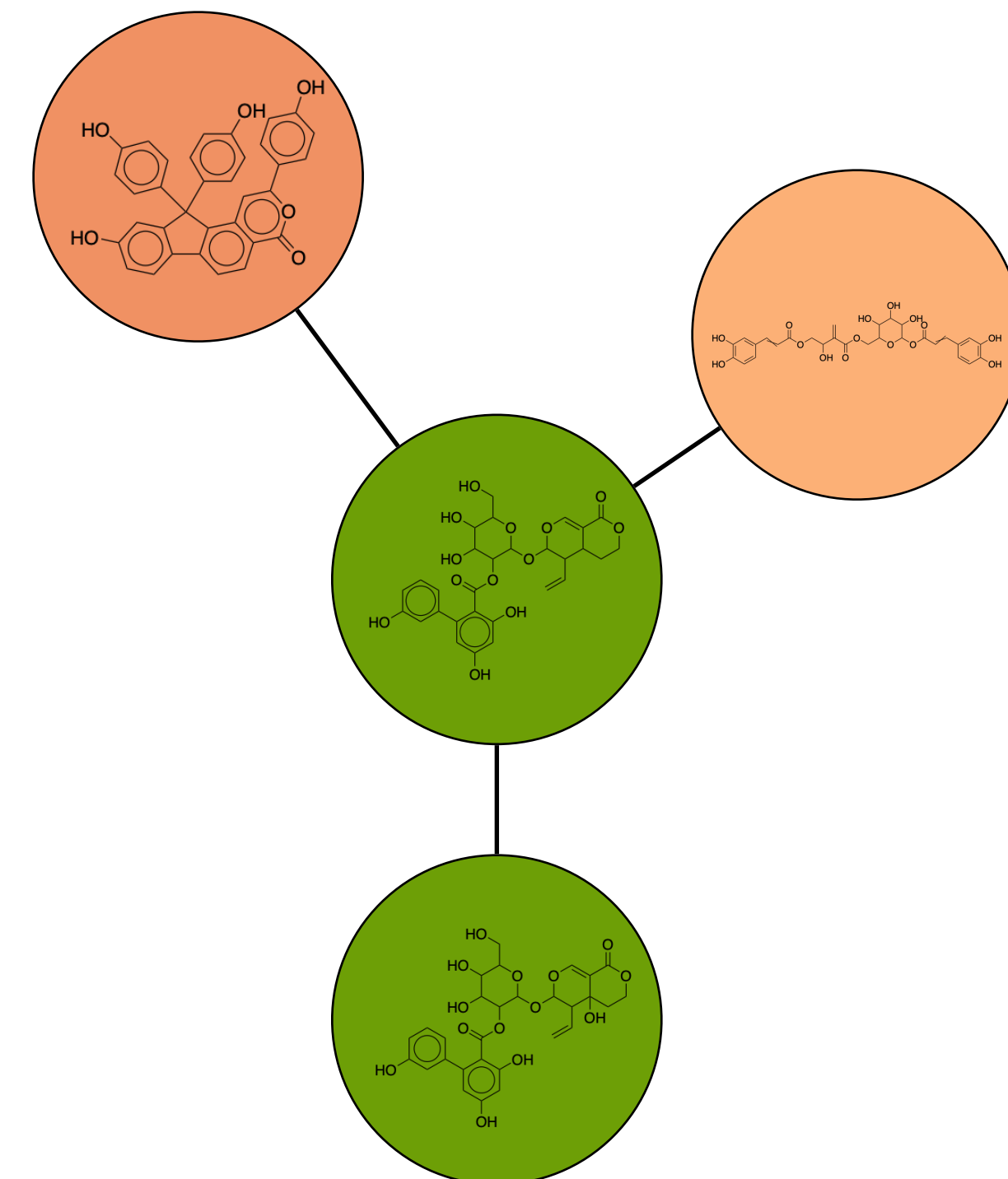

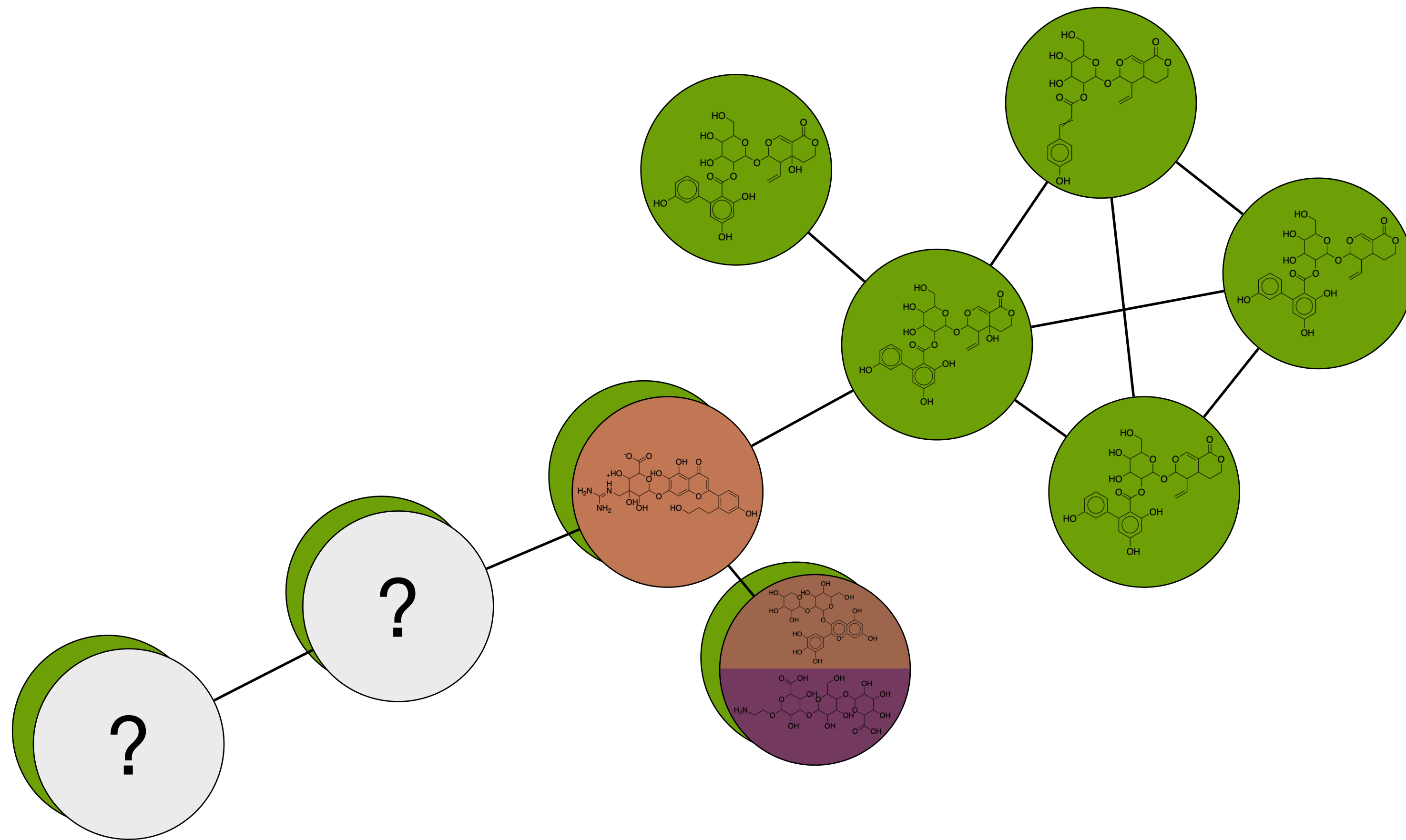

LOD-based annotation

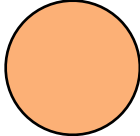
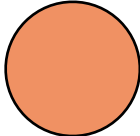
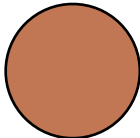
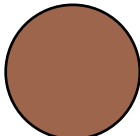
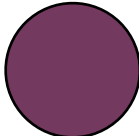

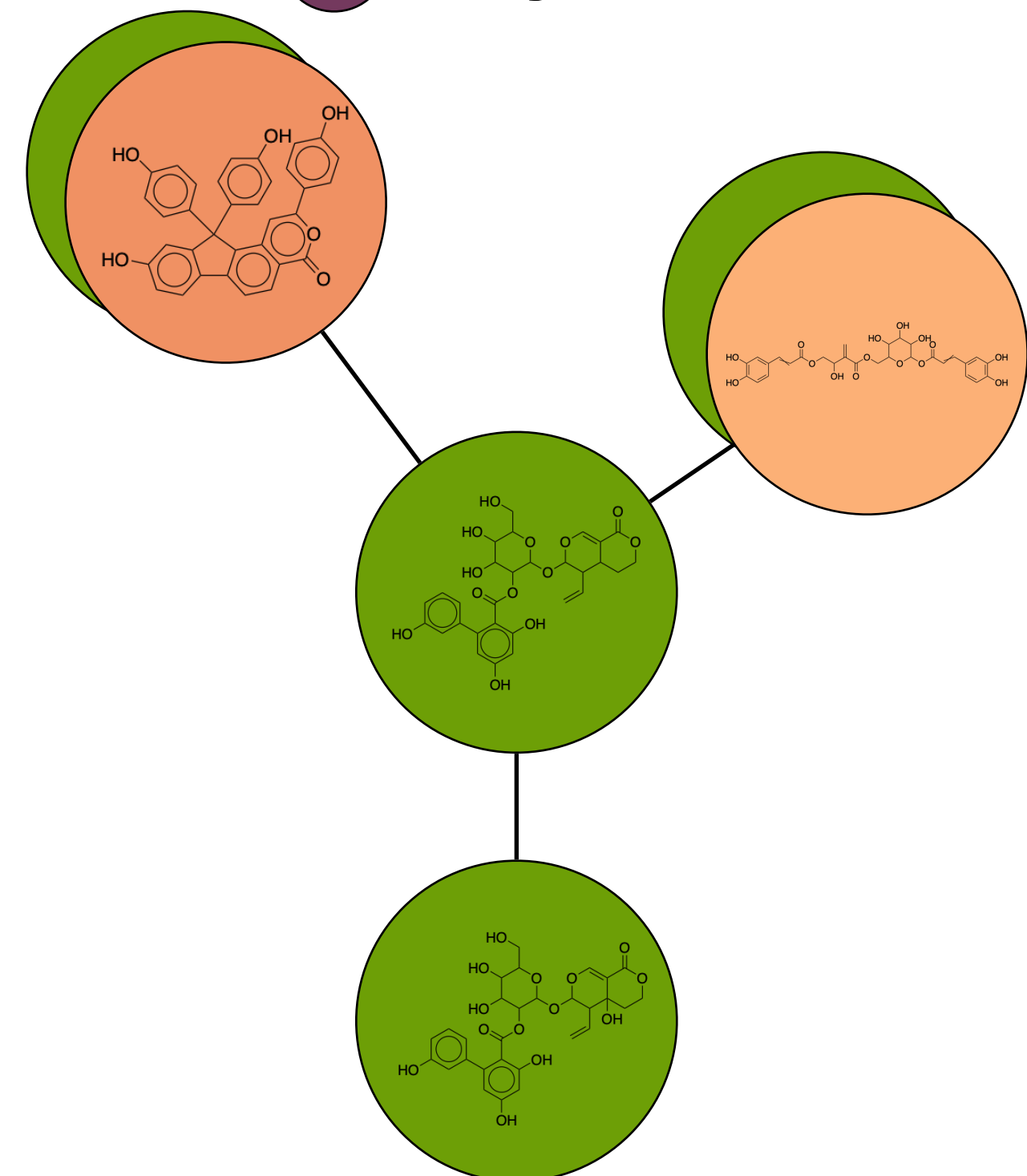
-  **Secoiridoid monoterpenoids**
-  **Cinnamic acids and derivative**
-  **Selaginellins**
-  **Flavones**
-  **Anthocyanidins**
-  **Polysaccharides**

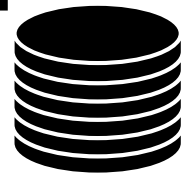

Optional MS¹-based
annotation



LOD-based annotation

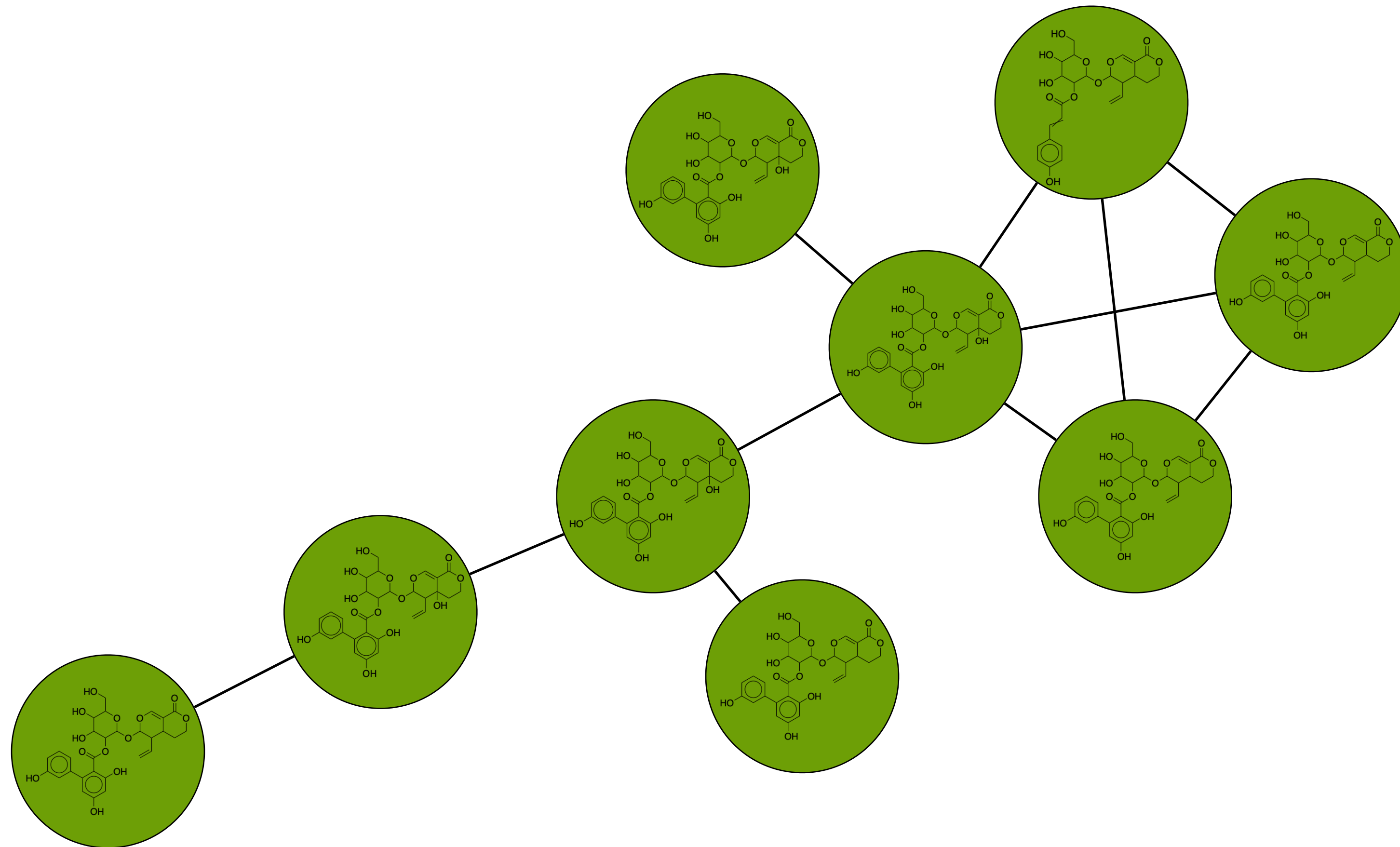

 **Secoiridoid monoterpenoids**

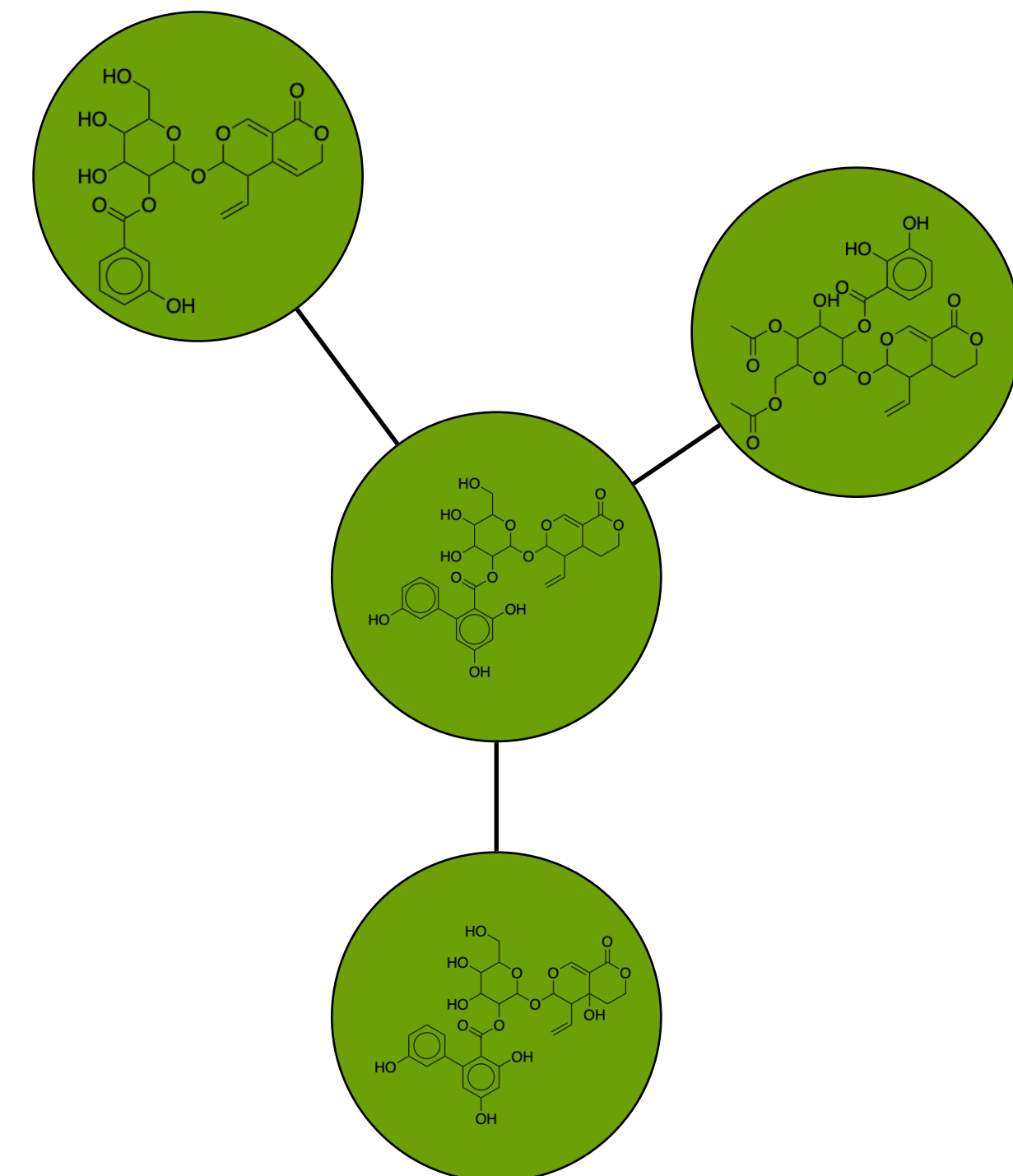

Optional MS¹-based
annotation



LOD-based annotation

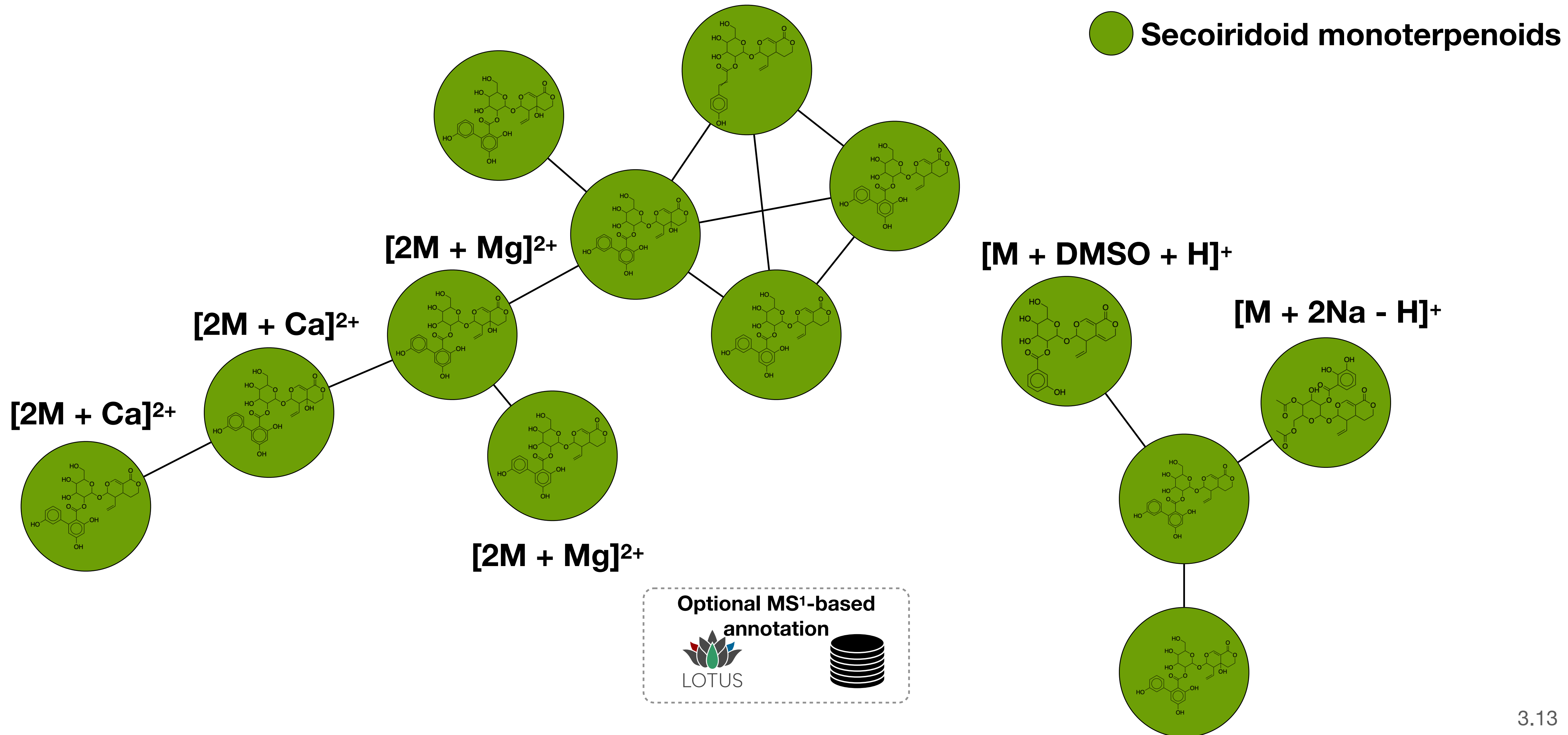

Previous annotation

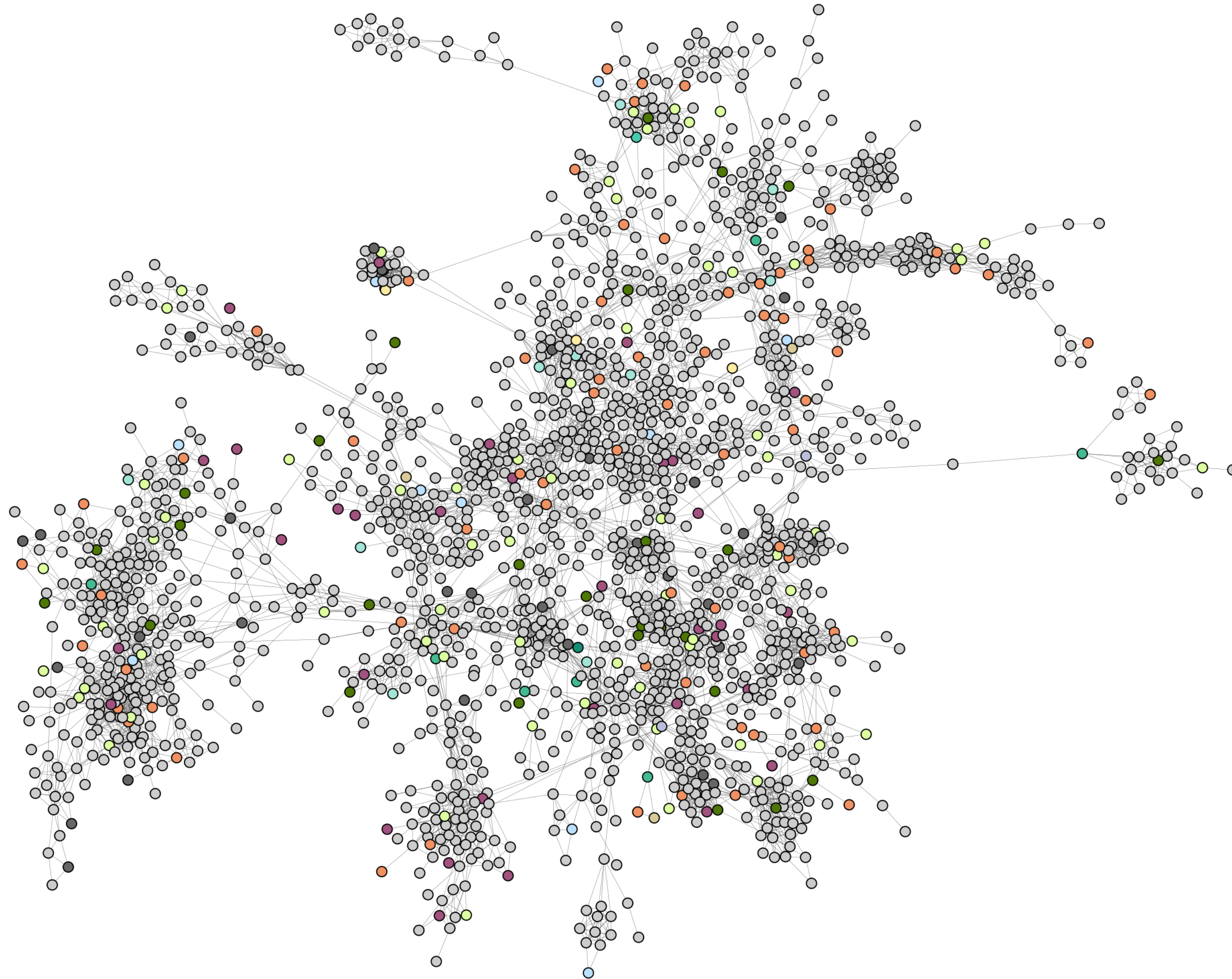

LOD-improved annotation

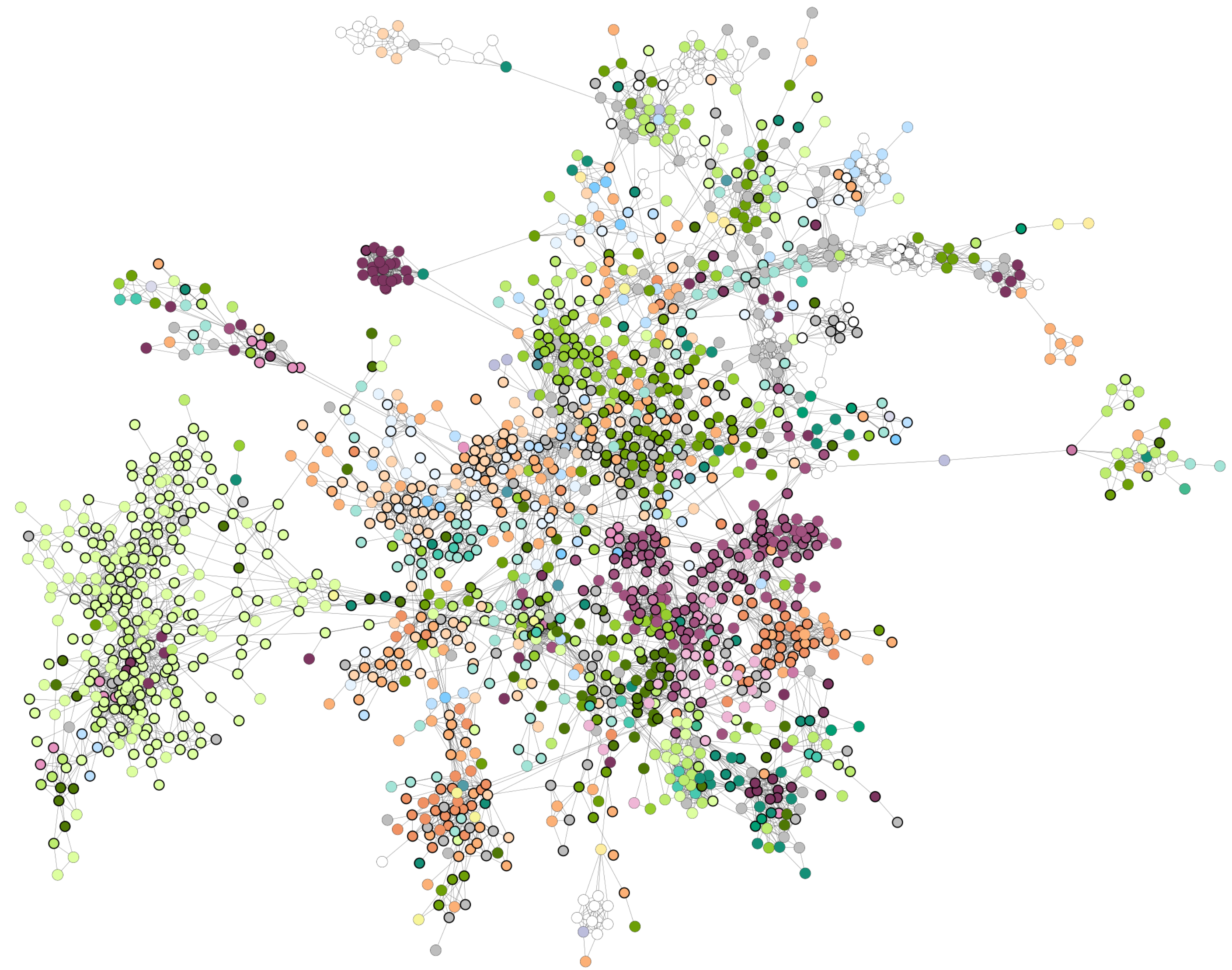

LOD has no limits

« Which researchers employed by research institutions in the country of the city after which Pilsner (Q152281) is named published articles referencing compounds found in taxa? (Top 10 compounds count) »



LOD has no limits

« Which researchers employed by research institutions in the country of the city after which Pilsner (Q152281) is named published articles referencing compounds found in taxa? (Top 10 compounds count) »

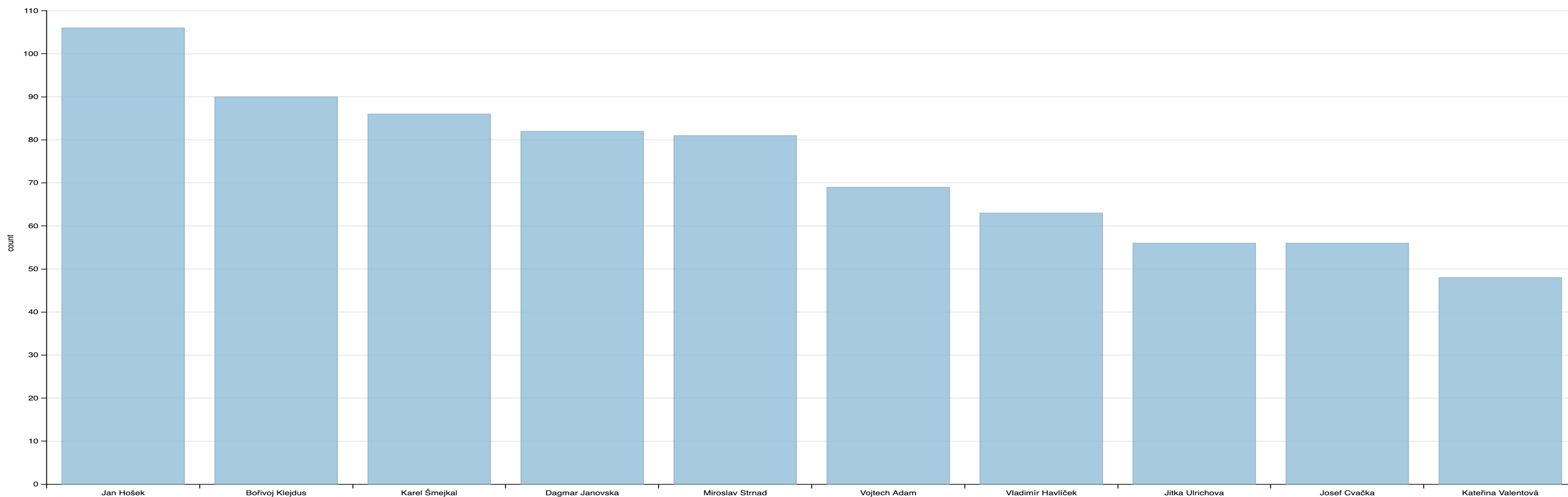

LOD has no limits

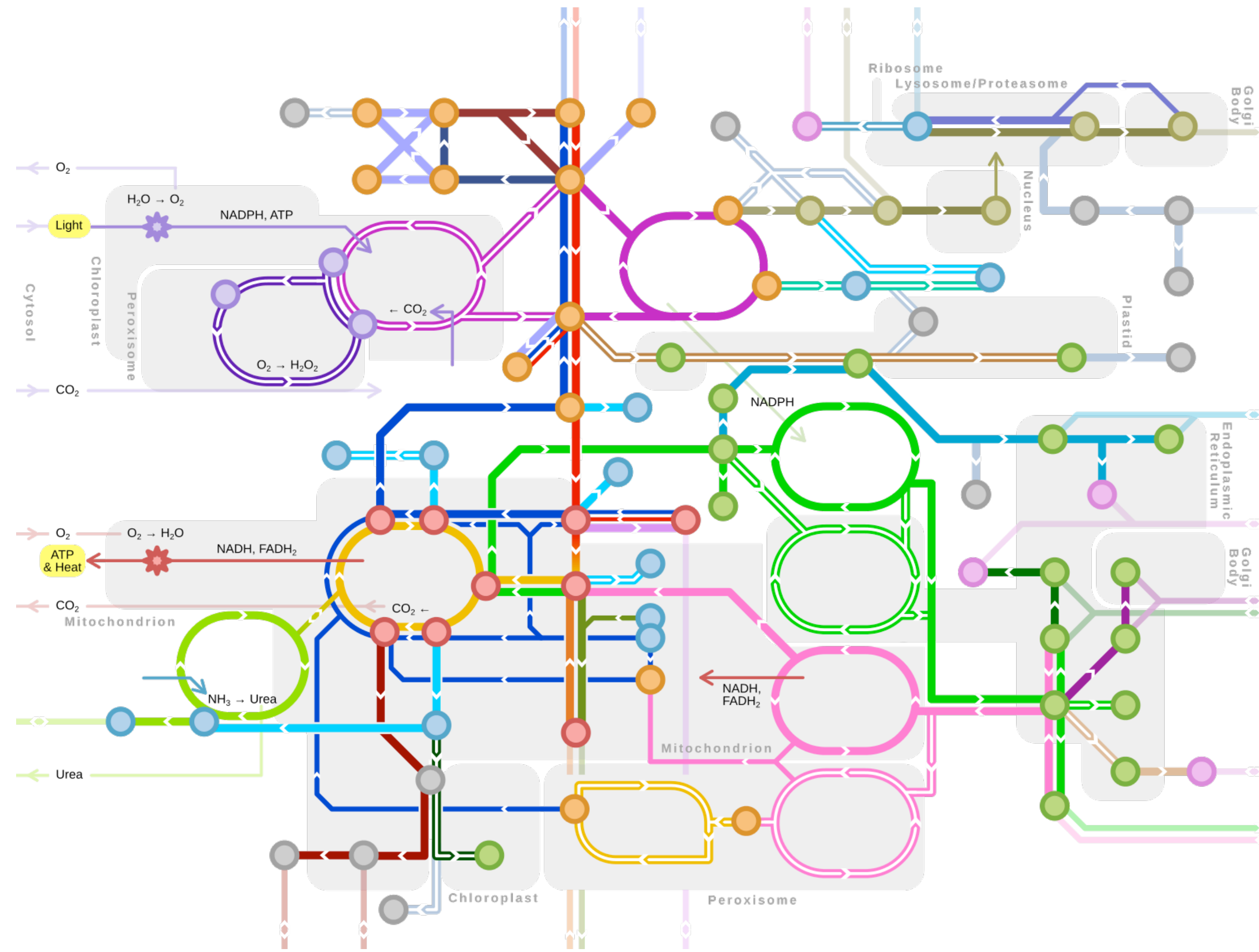

LOD has no limits

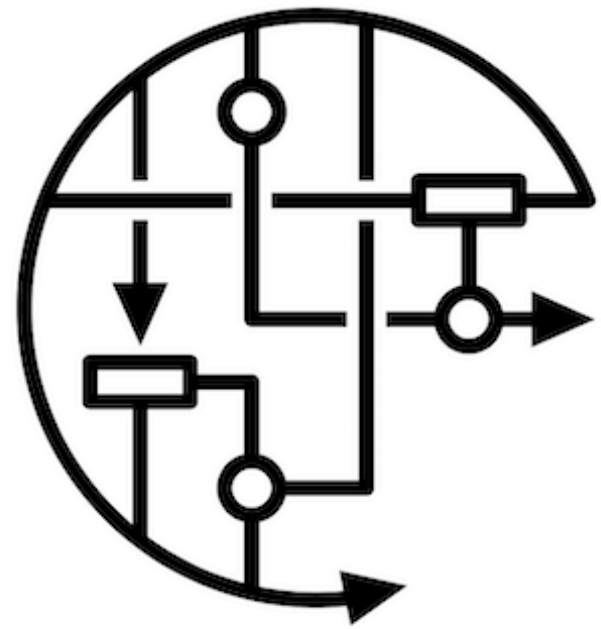

WIKIPATHWAYS
Pathways for the People

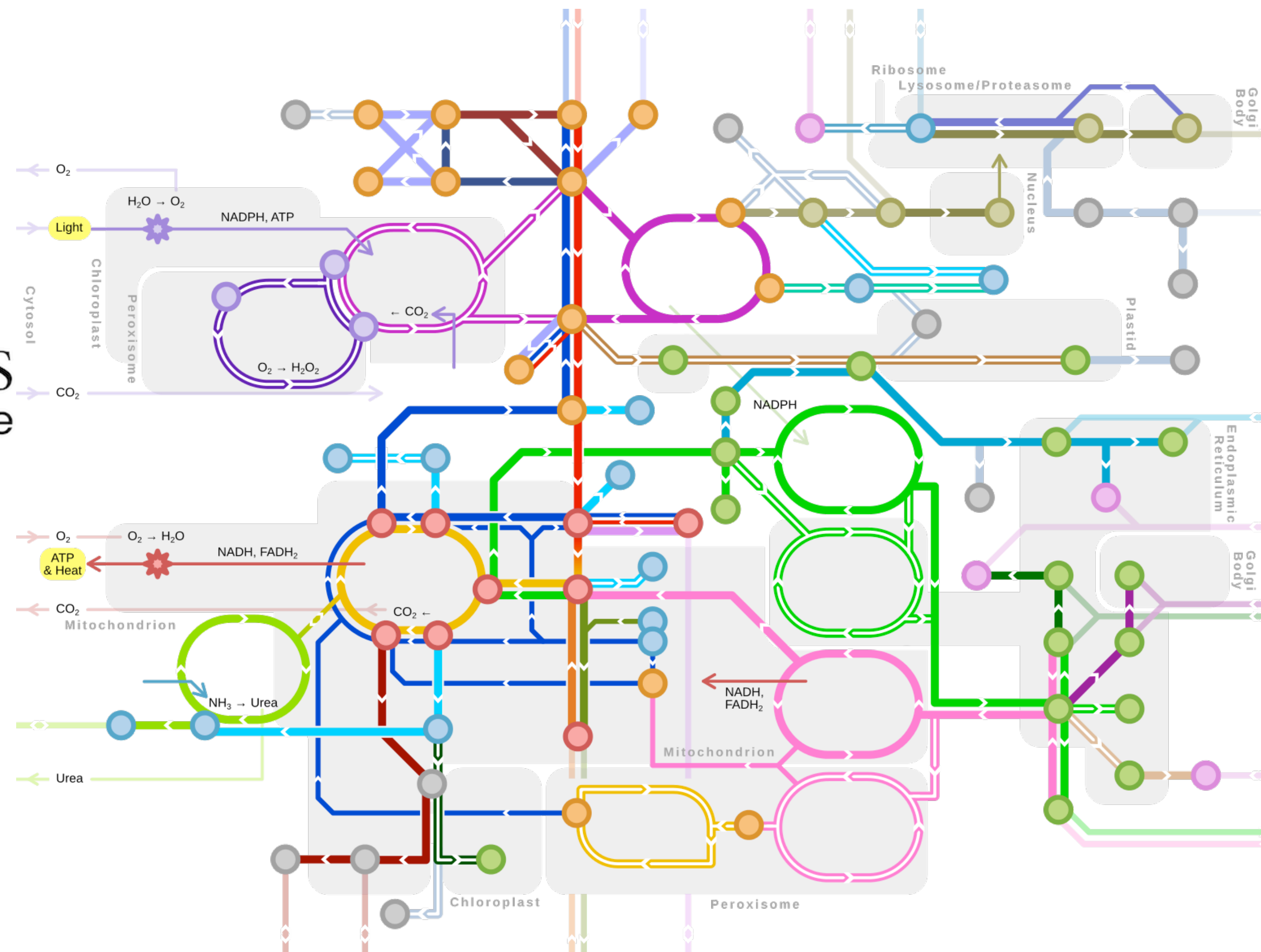

« Hey Wiki, are the metabolites I annotated known to interact with the cholesterol biosynthesis pathway? »

LOD has no limits

« *Hey Wiki, I saw this review¹ yesterday, could you do the same?* »



Contents lists available at [ScienceDirect](#)

Microbiological Research

journal homepage: www.elsevier.com/locate/micres



Actinobacteria in natural products research: Progress and prospects



Polpass Arul Jose^{a,*}, Anjisha Maharshi^{a,2}, Bhavanath Jha^{a,b,**}

^a Marine Biotechnology and Ecology Division, CSIR- Central Salt and Marine Chemicals Research Institute, G. B. Marg, Bhavnagar, Gujarat, 364002, India

^b Academy of Scientific and Innovative Research (AcSIR), CSIR, India

¹ <https://doi.org/10.1016/j.micres.2021.126708>

LOD has no limits

« Hey Wiki, I saw this review¹ yesterday, could you do the same? »

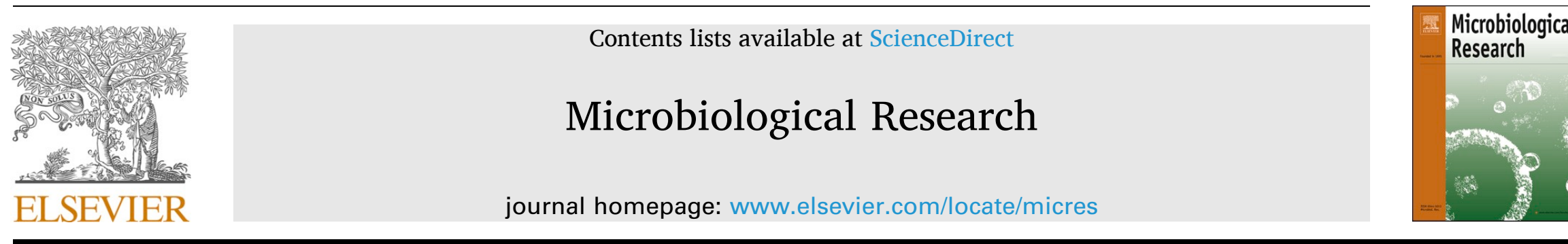

Which compounds with known bioactivities were isolated from Actinobacteria (Q26262282), between 2014 and 2019, with related organisms and references?

Actinobacteria in natural products research: Progress and prospects

Polpass Arul Jose^{a,*,1}, Anjisha Maharshi^{a,2}, Bhavanath Jha^{a,b,**}

^a Marine Biotechnology and Ecology Division, CSIR- Central Salt and Marine Chemicals Research Institute, G. B. Marg, Bhavnagar, Gujarat, 364002, India
^b Academy of Scientific and Innovative Research (AcSIR), CSIR, India



¹ <https://doi.org/10.1016/j.micres.2021.126708>

LOD has no limits

« Hey Wiki, I saw this review¹ yesterday, could you do the same? »

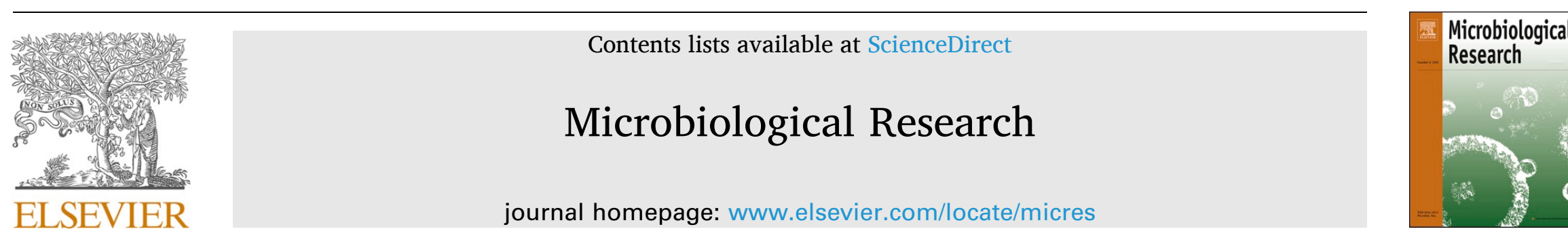

Actinobacteria in natural products research: Progress and prospects

Polpass Arul Jose^{a,*,1}, Anjisha Maharshi^{a,2}, Bhavanath Jha^{a,b,**}

^a Marine Biotechnology and Ecology Division, CSIR- Central Salt and Marine Chemicals Research Institute, G. B. Marg, Bhavnagar, Gujarat, 364002, India
^b Academy of Scientific and Innovative Research (AcSIR), CSIR, India

Table 1
Novel bioactive compounds isolated from Actinobacteria during last five years (2014-2019).

Organism	Compound	Bioactivity [#]	Reference
<i>Arthrobacter</i> sp. PGVB1	Arthroamide	f (anti-quorum sensing)	J Nat Prod. 2015;78:2827–2831
<i>Actinoallomurus</i> sp. ID145113 and 145,206	Paramagnetoquinones A–C (1–3)	(1/2) a; (3) a	J Nat Prod. 2017;80:819–827
<i>Actinoalloteichus hymeniacidonis</i> 179DD-027	Dokdolipid B	c	Mar Drugs 2019;17:237
<i>Actinomadura atramentaria</i> NBRC 14,695**	Cinnamycin B	a	J Ind Microbiol Biotechnol. 2016;43:1159–65
<i>Actinomadura</i> sp. BCC 35,430*	Actinomadurone	b	Tetrahedron Lett. 2017;58:3223–3225
<i>Actinomadura</i> sp. K13–0306	Sagamilactam	c, f (antiparasitic)	J Antibiot. 2016;69:818–824
<i>Actinomadura</i> sp. K4S16	Nonthmicin (1) & ecteinamycin (2)	(1,2) c	Org Lett. 2017;19:1406–1409
<i>Actinomadura</i> sp. KC191*	Actinomadurol	a	J Nat Prod. 2016;79:1886–1890
<i>Actinosynnema pretiosum</i> HGF052::asm18**	Actinosynneptide A (1) & B (2)	(1,2) c	Appl Microbiol Biotechnol. 2016;101:2273–2279
<i>Amycolatopsis</i> sp. IRD-009	Pradimicin-IRD	a, c	Natural Product Res. 2019;33:1713–1720

Which compounds with known bioactivities were isolated from Actinobacteria (Q26262282), between 2014 and 2019, with related organisms and references?

508 results in 4.8 seconds

Taxon name	Structure	Activity	Reference
<i>Streptomyces coelicolor</i>		Antibiotic immunosuppressive drug	10.1007/S11306-016-1025-6
<i>Saccharopolyspora erythraea</i>		Antibiotic protein synthesis inhibitors gastrointestinal agent	10.1021/ACSSYNBIO.8B00372
<i>Streptomyces venezuelae</i>		Antibiotic protein synthesis inhibitors	10.1016/J.JBIOTEC.2014.01.028

¹ <https://doi.org/10.1016/j.micres.2021.126708>

LOD has (almost) no limits

« Hey Wiki, I saw this review¹ yesterday, could you do the same? »

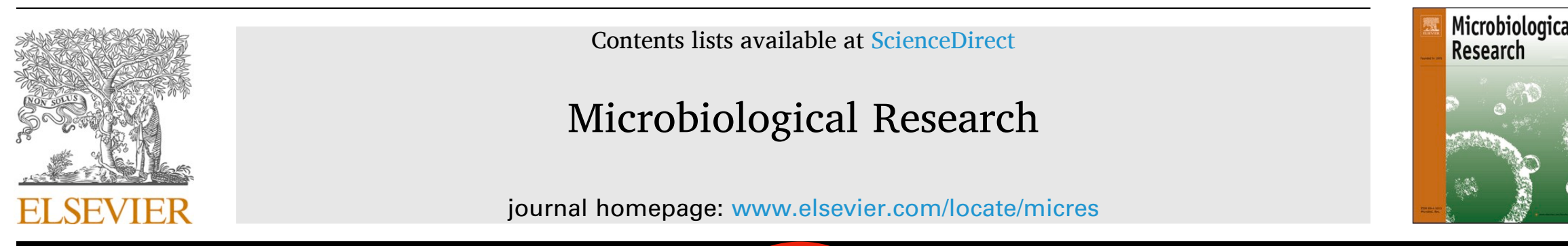

Actinobacteria in natural products research: Progress and prospects

Polpass Arul Jose^{a,*,1}, Anjisha Maharshi^{a,2}, Bh...

^a Marine Biotechnology and Ecology Division, CSIR- Central Salt and Marine Chemicals Research Institute, Marg, Bhavnagar, Gujarat, 364002, India
^b Academy of Scientific and Innovative Research (AcSIR), CSIR, India

Table 1
 Novel bioactive compounds isolated from Actinobacteria during last five years (2014-2019).

Organism	Compound	Bioactivity [#]	Reference
<i>Arthrobacter</i> sp. PGVB1	Arthroamide	f (anti-quorum sensing)	J Nat Prod. 2015;78:2827–2831
<i>Actinoallomurus</i> sp. ID145113 and 145,206	Paramagnetoquinones A–C (1–3)	(1/2) a; (3) a	J Nat Prod. 2017;80:819–827
<i>Actinoalloteichus hymeniacidonis</i> 179DD-027	Dokdolipid B	c	Mar Drugs 2019;17:237
<i>Actinomadura atramentaria</i> NBRC 14,695 ^{**}	Cinnamycin B	a	J Ind Microbiol Biotechnol. 2016;43:1159–65
<i>Actinomadura</i> sp. BCC 35,430 [*]	Actinomadurone	b	Tetrahedron Lett. 2017;58:3223–3225
<i>Actinomadura</i> sp. K13–0306	Sagamilactam	c, f (antiparasitic)	J Antibiot. 2016;69:818–824
<i>Actinomadura</i> sp. K4S16	Nonthmicin (1) & ecteinamycin (2)	(1,2) c	Org Lett. 2017;19:1406–1409
<i>Actinomadura</i> sp. KC191 [*]	Actinomadurol	a	J Nat Prod. 2016;79:1886–1890
<i>Actinosynnema pretiosum</i> HGF052::asm18 ^{**}	Actinosynneptide A (1) & B (2)	(1,2) c	Appl Microbiol Biotechnol. 2016;101:2273–2279
<i>Amycolatopsis</i> sp. IRD-009	Pradimicin-IRD	a, c	Natural Product Res. 2019;33:1713–1720

Which compounds with known bioactivities were isolated from Actinobacteria (Q26262282), between 2014 and 2019, with related organisms and references?

8 results in 4.8 seconds

Taxon name	Structure	Bioactivity	Reference
<i>Streptomyces coelicolor</i>		Antibiotic immunosuppressive drug	10.1007/S11306-016-1025-6
<i>Saccharopolyspora erythraea</i>		Antibiotic protein synthesis inhibitors gastrointestinal agent	10.1021/ACSSYNBIO.8B00372
<i>Streptomyces venezuelae</i>		Antibiotic protein synthesis inhibitors	10.1016/J.JBIOTEC.2014.01.028

¹ <https://doi.org/10.1016/j.micres.2021.126708>

LOD has no limits

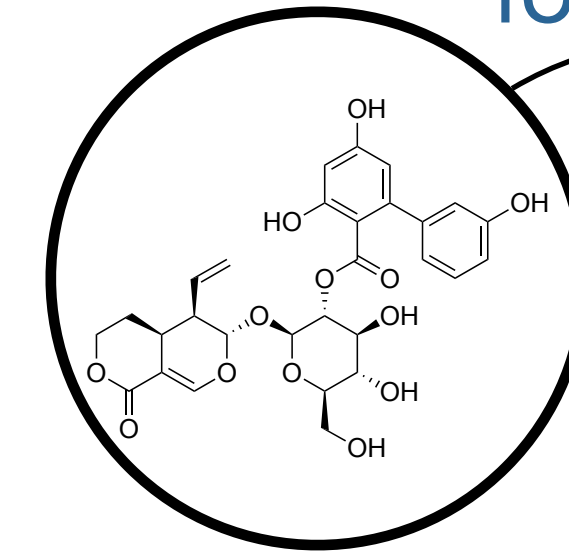

found in

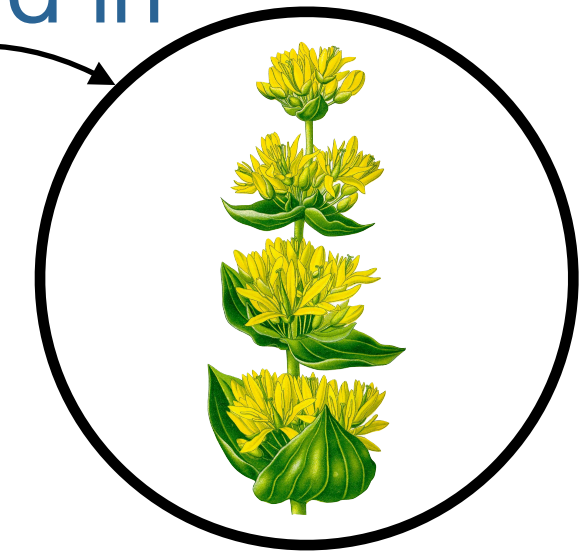

LOD has no limits

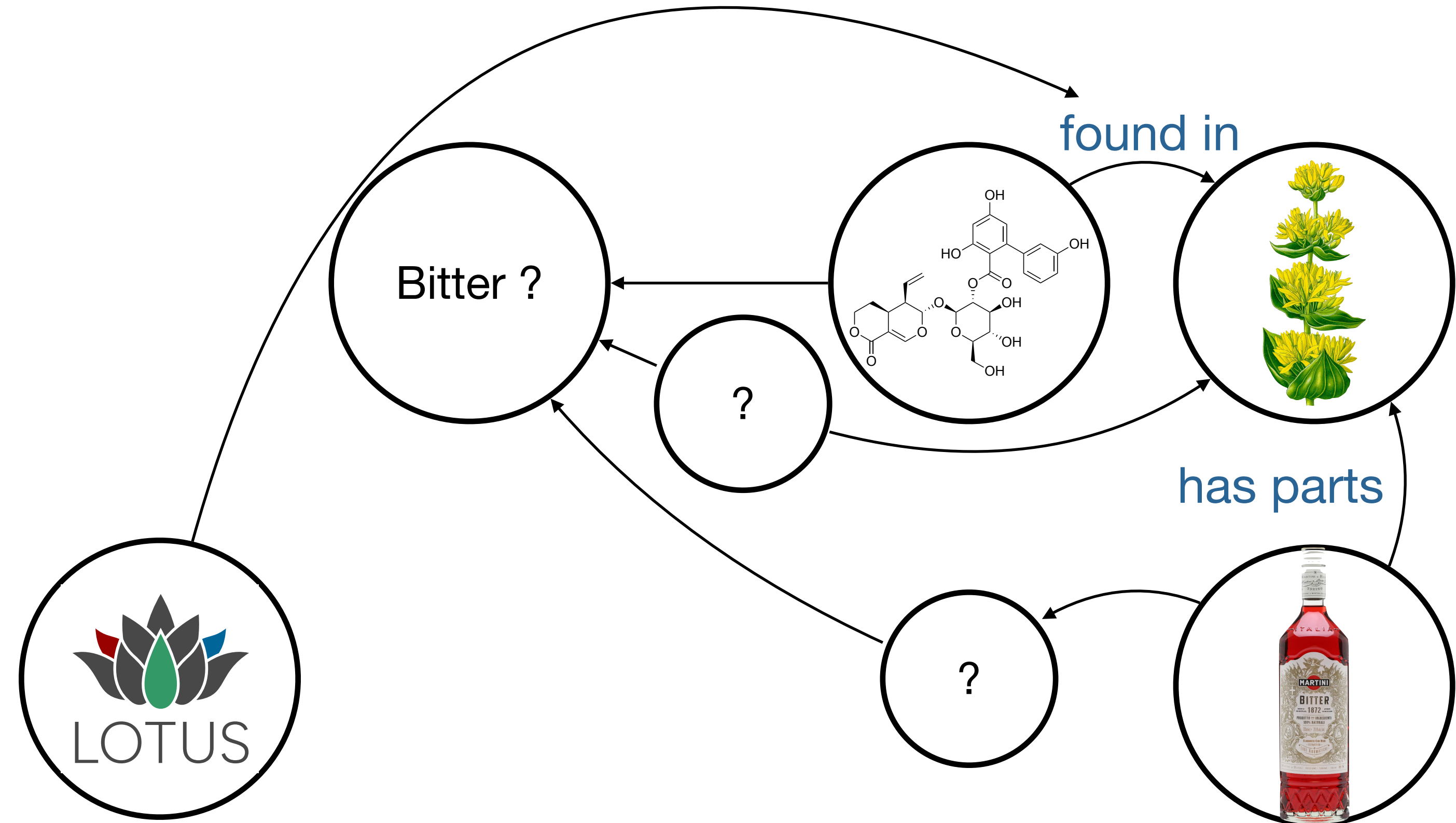

LOD has no limits

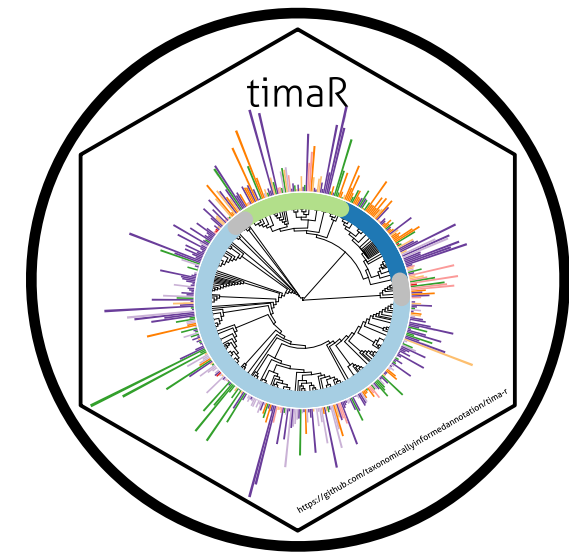

MS-based
dereplication

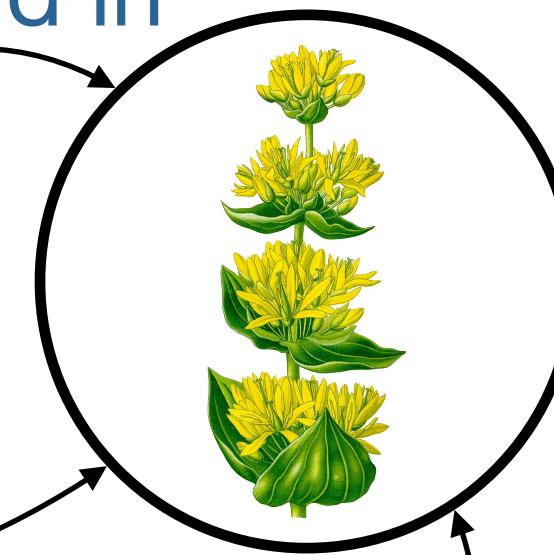
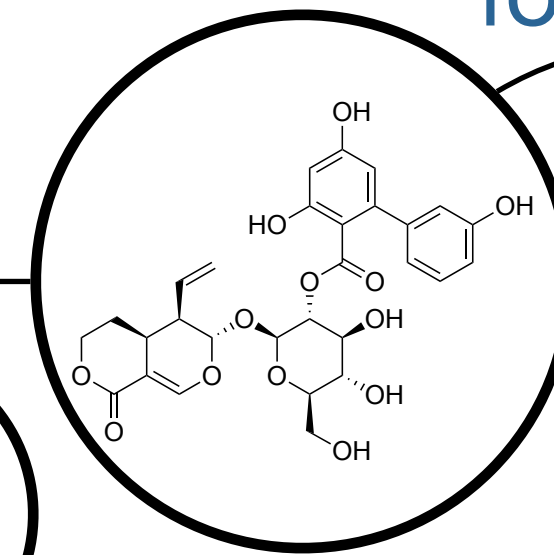
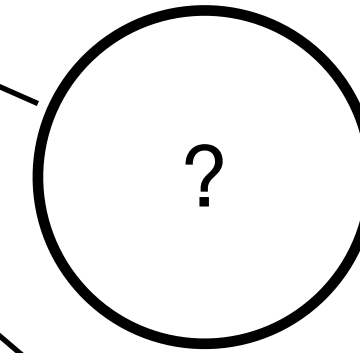
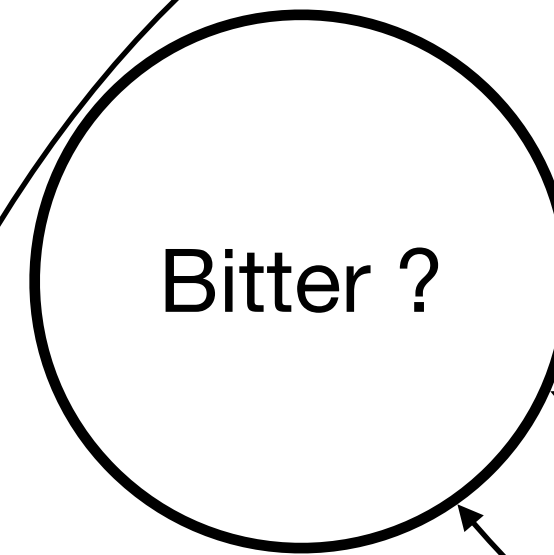
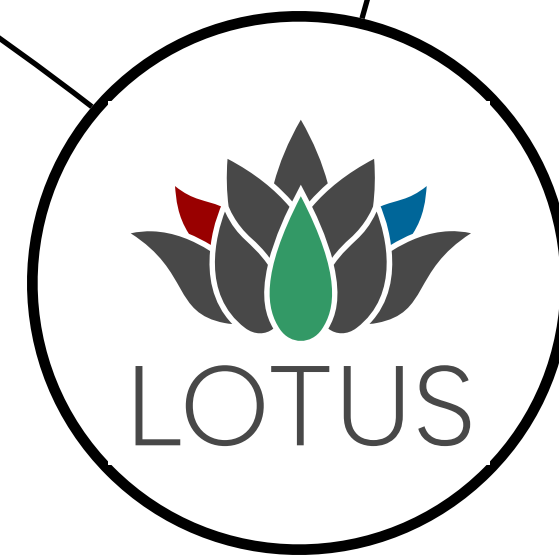

found in

has parts

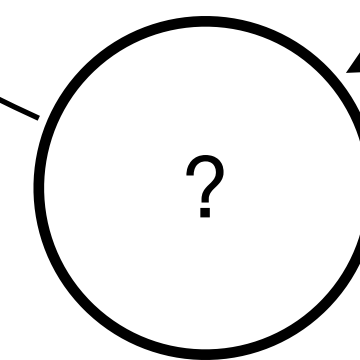

LOD has no limits

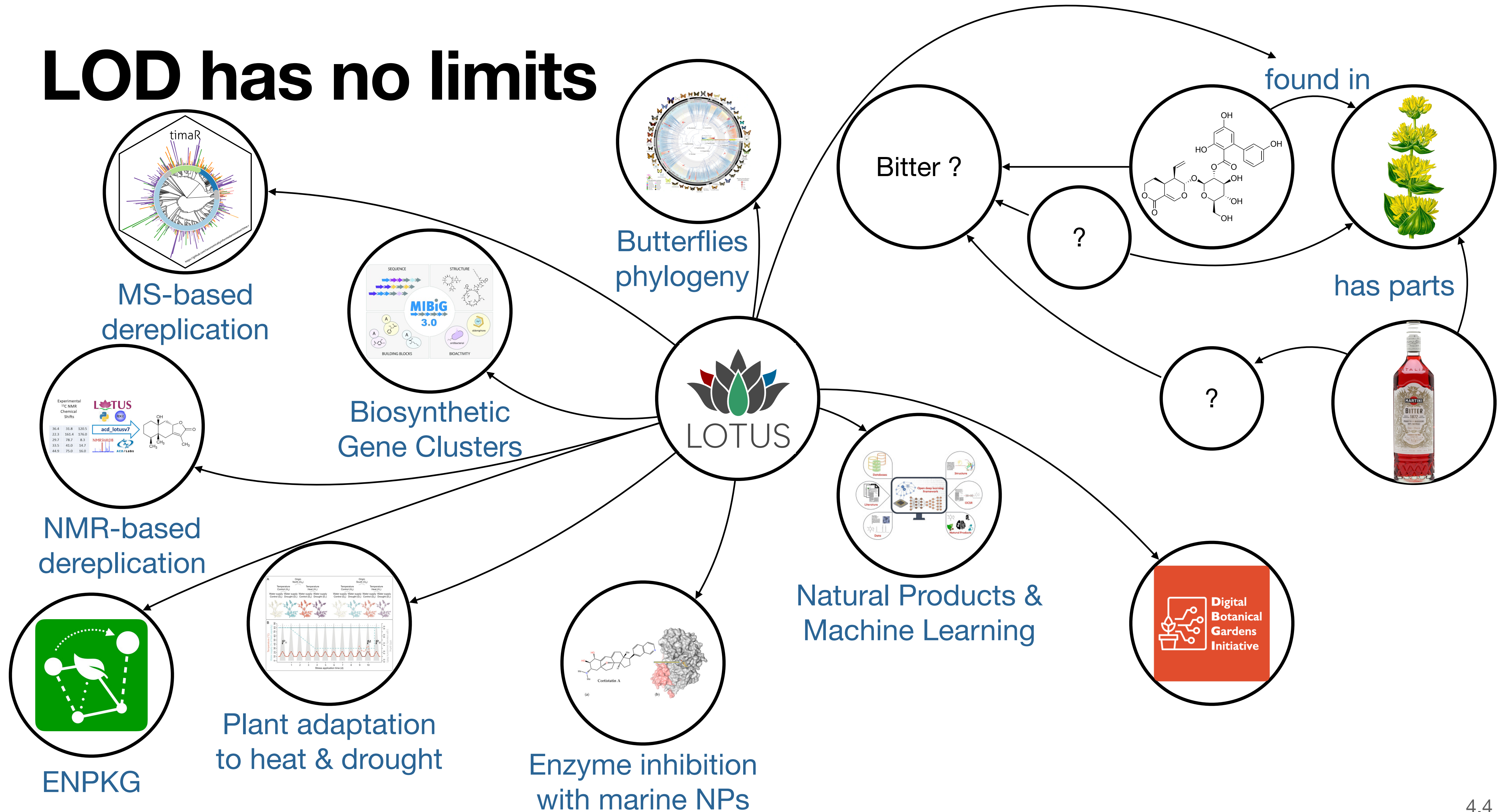

LOD has no limits

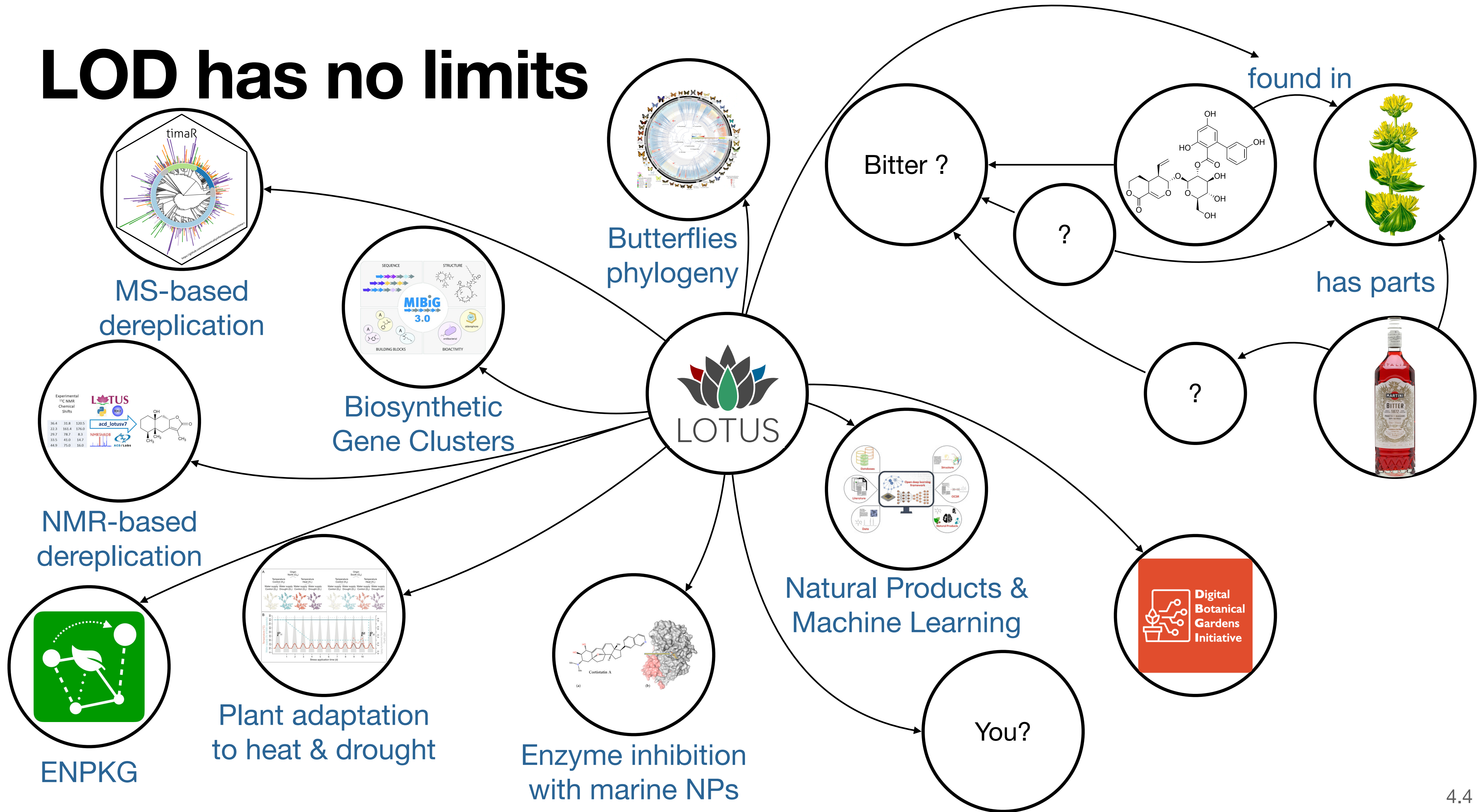

The Experimental Natural Products Knowledge Graph (ENPKG)

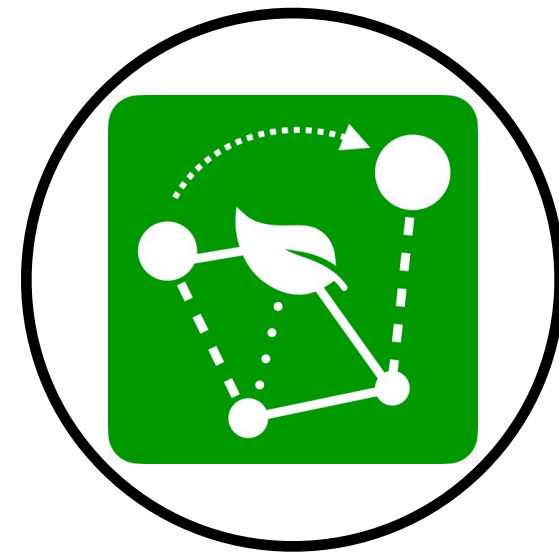

<https://enpkg.common-lab.org/>

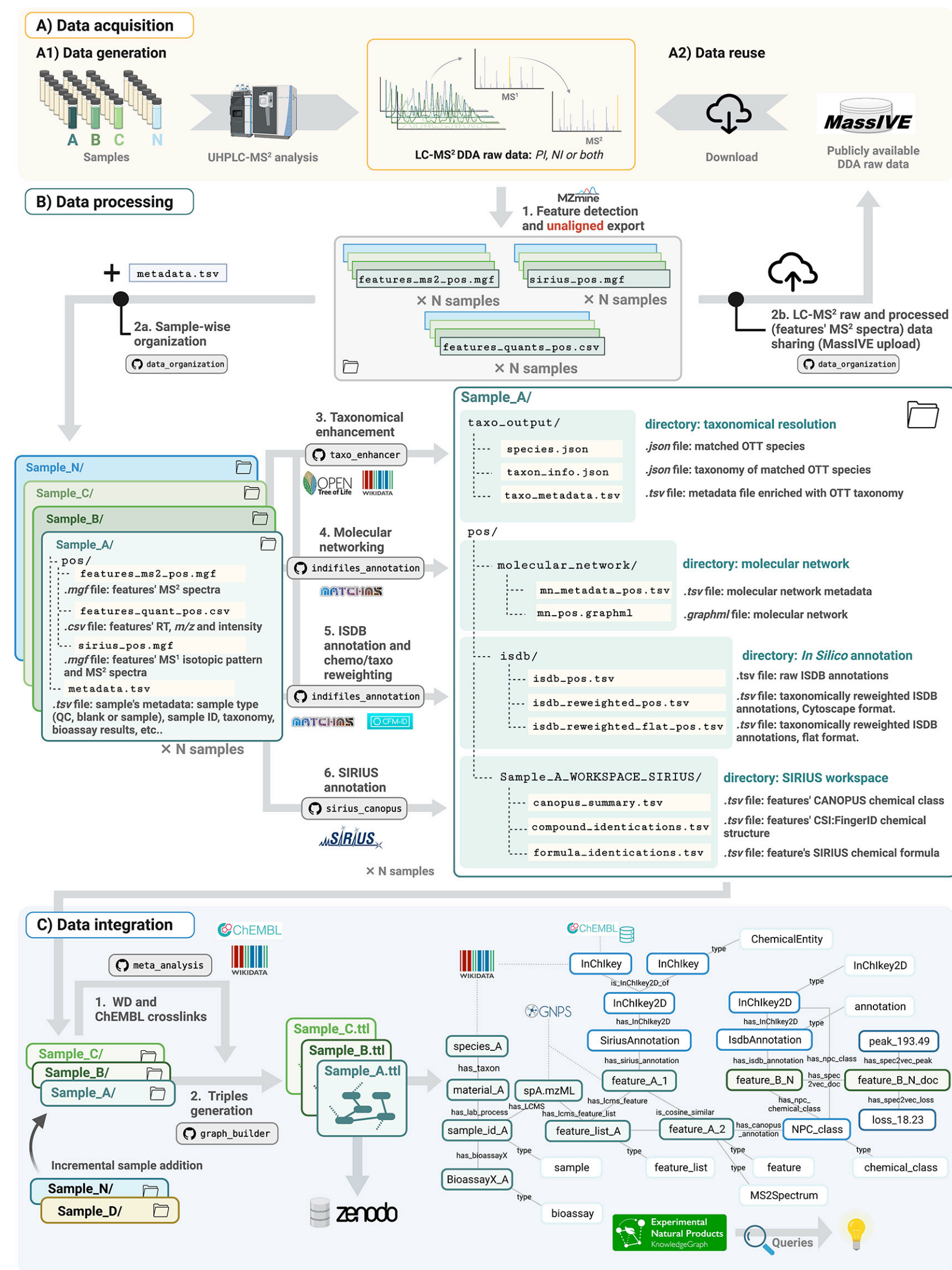

For more: <https://doi.org/10.1021/acscentsci.3c00800>

Acknowledgements



ETH zürich
D BIOL

Institute of Molecular Systems Biology



Prof. Nicola Zamboni

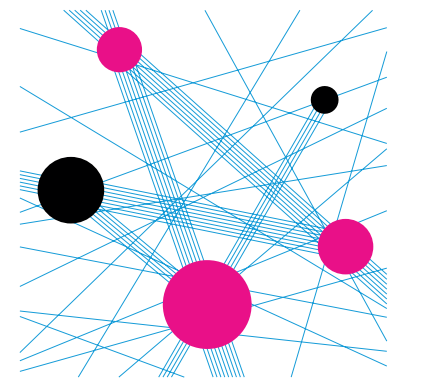

Contact



rutz@imsb.biol.ethz.ch